

SCHMEISER®

TRI PLANE LAND LEVELER

(INCLUDES RIGID AND FOLDING MODELS)

ASSEMBLY & PARTS MANUAL

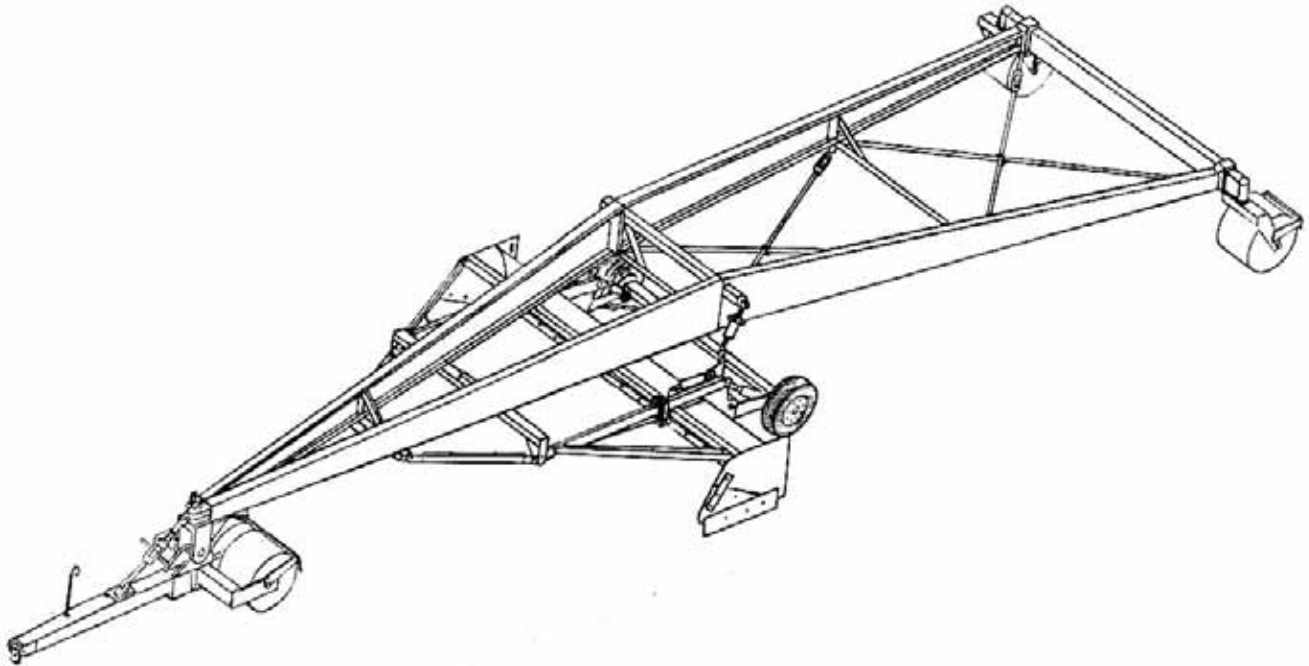

**12, 14, 16, & 18 FT. WIDE (RIGID)
20 & 24 FT. WIDE (FOLDING)
30 FT. & 40 FT. LONG**

T. G. SCHMEISER CO., INC.

**P.O. BOX 1047 FRESNO, CA 93714-1047
(559) 268-8128 FAX (559) 268-3279
www.tgschmeiser.com**

**VERSION 2.5
09 – 2011**

©COPYRIGHT 2011 T.G.SCHMEISER CO., INC.

INTRODUCTION

Your Schmeiser Tri Plane Land Leveler is designed to give you many years of dependable service. This manual has been prepared to instruct you in the safe and efficient operation of this machine. Read and study it thoroughly. Follow all instructions carefully.

Should your Tri Plane Land Leveler require replacement parts, go to your Schmeiser dealer. Always order genuine Schmeiser replacement parts.

It is important that you complete and send in your Warranty Card because it is not valid unless it is on file at Schmeiser. If you need information not contained in this manual, contact your Schmeiser dealer.

Space has been provided below for you to record the model number and serial number of your Tri Plane Land Leveler. Be sure to bring this information with you to your dealer when ordering parts for your Tri Plane Land Leveler.

Thank you for buying a Schmeiser Tri Plane Land Leveler.

SERIAL NUMBER _____

MODEL NUMBER _____

DATE PURCHASED _____

DEALER NAME _____

TABLE OF CONTENTS

Introduction.....	2
Table of Contents.....	3
Safety Instructions	4
Set Up Instructions.....	5
Land Leveler Road Transport	8
Land Leveling	8
Hydraulic Cylinder Option	9
Complete Assembly.....	10
Bucket Assembly	12
Bucket Bolt-Up Assembly	14
Bucket Linkage Assembly	16
Tongue Assembly	18
Main Frame Pivot Shaft Assembly	20
Front Turnbuckle Assembly	22
Front Steel Wheel Assembly	24
Rear Steel Wheel Assembly.....	26
Tire Axle Assembly	28
Tire Axle Hydraulic System Assembly	30
Hydraulic Bucket Lift System Assembly (Optional).....	32
Quad Tire Assembly (Optional).....	34
Appendix Folding Tri Plane Set-Up, Transport, and Leveling Instructions.....	36
Folding Tri Plane Bucket Assembly	40
Folding Tri Plane Rear Steel Wheel Pivot Frame Assembly.....	42
Folding Tri Plane Transport Lockout Assembly	43
Limited Warranty.....	44

SAFETY

The safe operation of any machinery is an important concern to farmers and manufactures. There are obvious and hidden potential hazards involved in the operation of this implement. Carefully read and follow all safety precautions before operation. Serious injury or death may occur unless care is taken to insure the safety of both the operator and any other persons in the area.

1. Never permit anyone to ride on or walk beside the implement when moving.
2. Never permit anyone to ride on tractor when implement is being moved.
3. Before starting machine, always check area around machine to verify that all personnel are clear.
4. Never connect hydraulic lines or operate any portion of the machine unless machine is hitched to tractor.
5. Do not operate hydraulic systems when hydraulic leaks are present.
6. Before transport or unhitching, always tie back hydraulic hoses.
7. Do not exceed 2000 psi working pressure or 2500 psi maximum pressure on hydraulic system.
8. When performing operating functions, never allow anyone to be near the implement or the tractor.
9. Do not enter tractor when tractor is moving. Avoid serious injury or death from contact with rotating tires. Enter and exit the tractor only when it is completely stopped.
10. Always operate machine in a careful, controlled manner.
11. Personnel operating and working with this machinery must not wear loose, dangling or unbuttoned clothing which could tangle in machinery.
12. Be sure of water, gas, sewer, or electric line locations before operating implement.
13. When in transport, use accessory lights and devices for adequate warning to operators of other vehicles.
14. Comply with all Federal, State and local laws when traveling on public roads.
15. Use "Slow Moving Vehicle" emblem for warning vehicles approaching from the rear.
16. When transporting, remember that the implement may be wider than your tractor and extreme care must be taken to allow for safe clearance.
17. Never allow inexperienced or untrained personnel to operate the implement or tractor.
18. When using compressed air to clean implement, wear safety glasses.
19. Check all fasteners for tightness or damage before and after operation. Repair immediately if required.
20. Before transport, inspect lug bolts and tire inflation.
21. Store implement in a stable position. Insure that safety stands are extended and locked in place before detaching from tractor. Before unhitching, place chocks in front and behind all transport wheels to prevent rolling when unhitched and parked.
22. Always use two people to handle heavy, unwieldy components during assembly, installation, removal, or moving.



THE FOLLOWING TOOLS ARE NEEDED:

- Truck with lifting boom, overhead hoist or forklift with 2000 pound lifting capacity.
- A 24" adjustable wrench or large pipe wrench.
- One 6" and two 12" adjustable wrenches.
- Socket wrench with 15/16" and 1-1/2" sockets.
- Heavy duty pliers.
- A heavy duty 12" screwdriver.
- A 14" tapered drift punch.
- A pry bar.
- A medium size ballpeen hammer.
- A ten-pound sledge hammer.
- Grease gun.

PROCEDURE:

1. Place the main frame with the front bearing clamp toward the front on level ground. Raise front and put wooden block about 4" high underneath it. Place the left rear main frame butt to butt with the left front main frame. Join together. Line up the mating holes and install (2) 1-1/4" NC x 4-1/2" Gr.8 bolts with lock washers and hex nuts and (1) 5/8" NC x 2" bolt with lock washer and hex nut in the hole near the bottom 1-1/4" NC bolt. Do not tighten.
2. Hoist the center cross frame (see drawing on page 11 – item # 20) up with sling or chain attached to the 3" x 3" tube so that the cross frame is parallel to the ground and oriented to the square hole in the upper middle section of the left main frame. Line up the mating holes on the main frame and install (2) 1-1/4" NC x 4-1/2" Gr.8 bolts with lock washers and hex nuts and (1) 5/8" NC x 2" bolt with lock washer and hex nut in the hole near the bottom 1-1/4" NC bolt. Make sure the cross frame is positioned so that the attaching bracket on the bottom side of the 3" x 3" square tube is flush on the side facing the forward end of the machine. Now slide the end of the square tube through the square hole in the frame until the two attaching holes match up. Install one 1" x 4" bolt with lock washer and hex nut and one 1" x 3" bolt with lock washer and hex nuts. Do not tighten. Keep center cross frame suspended.
3. Place the right rear main frame butt to butt with the right front main frame. Join together. Be sure that the end of the center cross frame square tube goes through the square hole in the right side of the main frame until the two attaching holes match up. Install one 1" x 4" bolt with lock washer and hex nut and one 1" x 3" bolt with lock washer and hex nuts. . Line up the mating holes on the main frame and install (2) 1-1/4" NC x 4-1/2" Gr.8 bolts with lock washers and hex nuts and (1) 5/8" NC x 2" bolt with lock washer and hex nut in the hole near the bottom 1-1/4" NC bolt. Do not tighten.
4. Install rear inside frame (see drawing on page 11 – item # 27). Use (4) 5/8" NC x 2" bolts, lock washers and hex nuts. Tighten all bolts securely.
5. Lift up front of the machine. Open up front clamp BC-100 and install the front steel wheel frame and main frame pivot shaft assembly (with bearing housing, thrust bearing, inner races, pin bearings,

shaft cap, oil seal & dust cap) into the bearing clamp opening on the front end of the right and left main frames. Join the bearing clamps together and line up the six mating holes. Install six 3/4" NC x 2" bolts, lock washers and hex nuts. Tighten up enough to hold bearing housing in place.

6. Install front pivot shaft lockout (with two slotted holes). See drawing on page 11 - item # 8. Use two 3/4"NC x 2" bolts, flat washers, lock washers and hex nuts. Tighten securely. Place lock pin in position.
7. Position rear cross frame with attached steel wheels against the mounting plates on the rear end of the main frame. Guide stops on the rear cross frame should be next to mounting plates on the main frame. Adjust main frame height (if necessary) so that the two 8" U-bolts (see drawing on page 11 – item # 31) can be placed around the rear cross frame tube and inserted through the four mating holes in the end plate of the rear main frame. Install four 7/8" NF hex nuts and lock washers. Make necessary sideways adjustments and tighten securely.
8. Put bucket with attached bucket arms beside main frame with pull arms facing forward. Place piece of pipe underneath bucket. Push bucket from one end under main frame until bucket arms align with bucket cross brace. Fasten with 1" x 4" bolts and nylon lock nuts. Do not tighten.
9. Mount top turnbuckle stub (see drawing on page 17 – item # 6) to center cross frame using 1/2" x 1-1/2" bolt with lock washer and turnbuckle end plate. Tighten securely.
10. Screw turnbuckle body (see drawing on page 17 – item # 5) onto top stub leaving 4" of thread showing. Screw in lower turnbuckle stub (see drawing on page 17 – item # 4). Leave about 4" of thread showing.
11. Attach longer end of T-Bar link (see drawing on page 17 – item # 3) to lower turnbuckle stub using 1" x 3-1/2" bolt with zerk fitting and secure with 1" nylon lock nut.
12. Install adjustment rod (see drawing on page 17 – item # 1) on the bucket using (2) 1" jam hex nuts.
13. Mount one end of straight link (see drawing on page 17 – item # 2) to adjustment rod using 1" x 3" bolts with lock washers and hex nuts. Do not tighten.
14. Connect top hole of bucket axle clevis plate with bottom hole of T-Bar link using 1" x 6-1/2" bolt with zerk fitting and secure with 1" nylon lock nut. Line up other end of straight link with the T-bar link end hole. Lift front section of the machine from under main frame until bucket turnbuckle is in vertical position and the mating holes line up. Install 1" NC x 3" bolt with zerk fitting; then install 1" nylon lock nut. Make sure the grease fitting is facing out.
15. Tighten adjustment rod jam nuts and 1" hex nut. Make sure that all bolts with nylon lock nuts are secure but able to move.
16. Repeat same procedure for the other side.
17. Push the tire axle (see drawing on page 11 – item # 22) under the main frame. Align the tire axle so that when mounted to the rear of the bucket, the cylinder anchors are on the backside toward the rear cross frame. Now push the tire axle up until the legs slide into the gussets on the rear of the bucket. Line up the holes and insert a 1" NC x 3-1/2" bolt with zerks, through each hole. Install a nylon lock nut on each bolt and tighten.

18. Install hydraulic pipe with attached flow divider from the back side of the machine sliding it under center cross frame toward the front. Place the second hydraulic pipe on top and secure with double pipe clamps.
19. Attach 3" x 8" welded hydraulic cylinders (see drawing on page 31 – item # 11) with rod ends facing away from bucket to the tire axle.
20. Install 41" hoses into the lower port of the cylinders and upper set of cross pipes. Install the 33" hoses into the upper port of the cylinders and the lower set of cross pipes. Use thread sealant on all pipe and hose joints. Support the piping with five double pipe clamps. Use five 5/16" NC x 2-1/2" bolts, lock washers and hex nuts.
21. Install two short cross rods between the center cross frame and the rear inside frame. Use two 5/8" NC x 2" bolts, lock washers and hex nuts at center cross frame and two 5/8" NC x 2" bolts, lock washers and hex nuts at the rear inside frame end. Leave the rod assemblies loose.
22. Now install the two long cross rods between the rear inside frame and the rear cross frame. Use two 5/8" NC x 2" bolts, lock washers and hex nuts at the rear end of the main frame and two 5/8" NC x 2" bolts, lock washers and hex nuts at the rear inside frame end. Leave the rod assemblies loose.
23. Tighten up all eight cross rod attaching bolts.
24. Tighten up all four cross rod turnbuckles sufficiently to square up the frames. Install the cross rod U-bolts (see drawing on page 11 – item # 35).
25. Make a final check of the assembled Land Leveler. Cross rods should be tightened. The jam nut should be locked up against the turnbuckle. The front turnbuckle must be adjusted correctly. Lock pins should be in place. Make sure all frame and cross member bolts are tight. 8" U-bolts must be tight and positioned correctly on the rear cross frame. Grease all zerck fittings prior to operation.

TO TRANSPORT THE LAND LEVELER ON THE ROAD:

1. Move the bucket to its lowest position, then install the cylinder locking bars. The tire axle will be up and lock pins in place. Remove both lock pins from the tire axle. Lower the tire axle hydraulically until the lock pins can be reinserted into the same holes. This will lock the wheels into the transport position with the rear steel wheels off the ground.
2. Align the tongue with the frame center line, then insert the pivot shaft lockout pin, with the wrench portion up, between the frames and through the rear hole of the front main frame pivot shaft.
3. Adjust the front turnbuckle to hookup to the tractor drawbar, and then readjust for the wheel/ground clearance desired.
4. **DO NOT TRY TO MOVE THE LAND LEVELER ON THE ROAD ON ITS STEEL WHEELS OR QUAD RUBBER TIRES. Always use the transport wheels when moving on roadways.**

TO LOWER LAND LEVELER FOR LAND LEVELING:

1. Lower the tire axle hydraulically enough to remove the locking pins. Raise the tire axle slowly until the front or rear wheels touch the ground. Adjust the front turnbuckle until the pins are free. Remove the turnbuckle and mount it on the left pull brace with two lynch pins.
2. If the machine does not have a hydraulically actuated bucket, lift arm locks must be used on each side.
3. Remove the pivot shaft lockout pin, the 1" shaft between the front ends of the frame; place it in the pin holder bracket at the front of the machine.
4. The bucket leveling and depth adjustments are made by adjusting the lift screws located on each side of the Land Leveler.
5. Check the rear wheels for travel alignment:
 - a. Loosen both stabilizer bearing cap screws to assure that the bearing or roller is free to move in the slot.
 - b. Stretch a string from the outside of one wheel rim to the outside of the opposite wheel rim approximately 14" off of and parallel to the ground.
 - c. Adjust each wheel so that the string touches the full surface of each wheel rim with no bend in the string. (Visually check from outside of one wheel to the outside of the other)
 - d. Retighten the bearing or roller cap screws in the stabilizer.
 - e. Remove the string and now the Land Leveler is ready to use.
6. Operating the machine under adverse conditions, such as extremely rough ground, rocks or stumps, may cause the hitch end bolt to break. If this occurs, do not replace the factory installed bolt with a case hardened bolt. It is intended to be a safety shear pin.
7. **Hydraulic Cylinder option.** Adjust cylinder adjusting screw, located on the piston end of the bucket cylinder, so that the pivot point (A) is located 1/8" forward of a direct line between the upper turnbuckle; attach point (B) and the lower attach point (C) on each side of the machine. (See Drawing on the following page)
8. Adjust the bucket lift turnbuckle to "Level", set blade and working height of the bucket.
9. Recheck adjustment No. 7 above, to make sure pivot point is within tolerance (0" to 1/8"). If necessary, readjust No. 7 and No. 8 above.

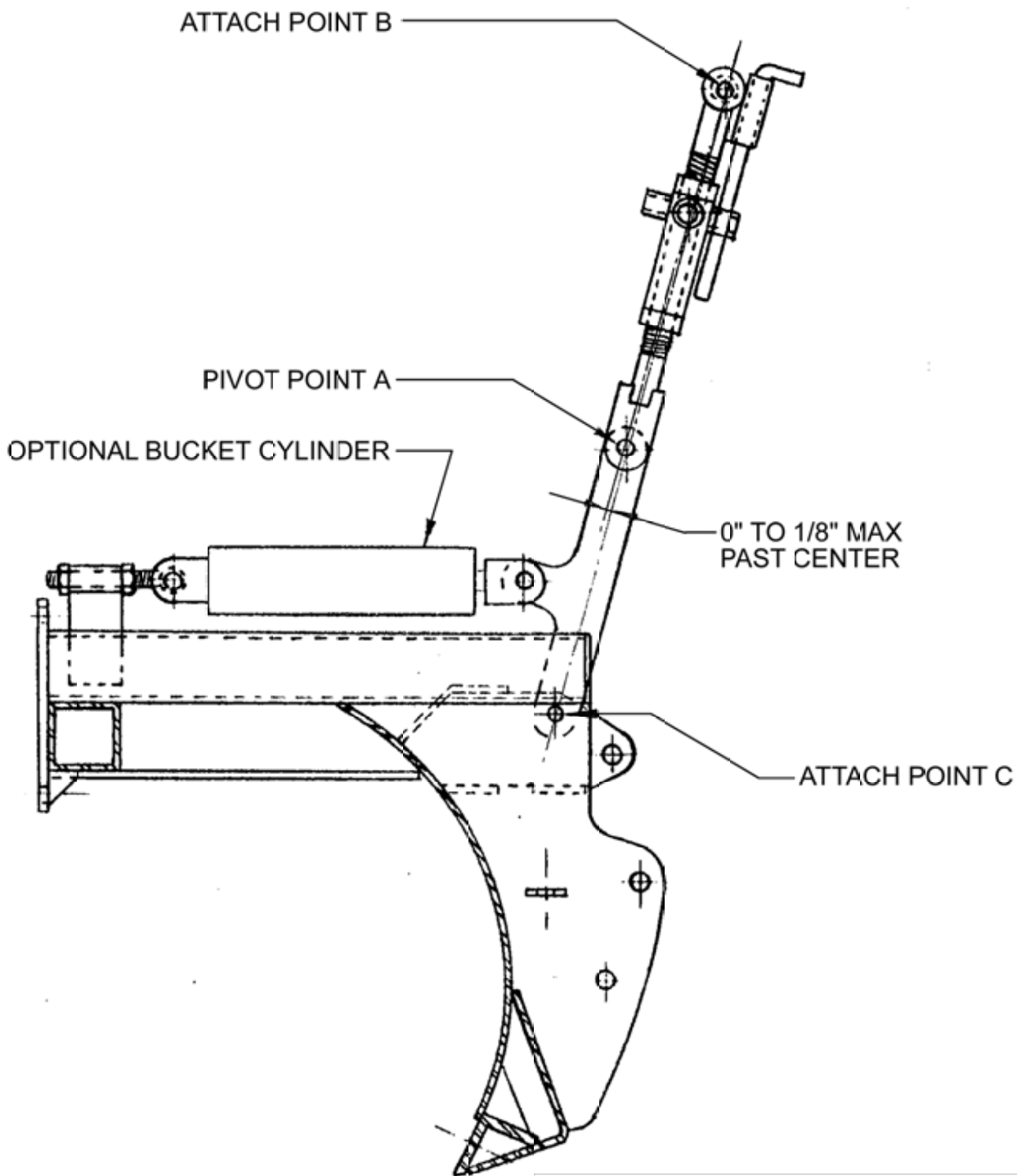



Item #	Old Part #	New Part #	Description	Q-ty	
				40'	30'
1	SLP-Q2	SLP-00Q200	Tongue Hitch	1	1
2	SLP-Q1	SLP-00Q100	Tongue	1	1
3	SLP-Q5	GHD-HHOLD1	Hydraulic Line Support	1	1
4	SLP-Q4	SLP-00Q300	Front Turnbuckle Assembly	1	1
5	SLP-N	SLP-00N000	Main Frame Pivot Shaft	1	1
6	SLP-P1	SLP-00P100	Front Steel Wheel Frame	1	1
	SLP-P2	SLP-00P400	Quad Tire Frame (Optional)	-	-
7	SLP-D	SLP-00D000	Steel Wheels	4	4
8	SLP-A8	SLP-00A800	Pivot Shaft Lockout	1	1
9	SLP-A9	SLP-00A900	Pivot Shaft Lockout Pin	1	1
10	SLP-A1R	SLP-00A100R	Top Frame, Front - R.H.	1	1
11	SLP-A1L	SLP-00A100L	Top Frame, Front - L.H.	1	1
12	SLP-P1-9	SLP-00P200	Front Scraper Blade	1	1
13	SLP-G	SLP-00E100	Front Cross Frame	1	1
14	SLP-J2R	SLP-00J200R	Pull Brace R.H.	1	1
	SLP-J2L	SLP-00J200L	Pull Brace L.H.	1	1
15	SLP-J1	SLP-00J100	Cross Brace - T.F. to Bucket	1	1
16	SLP-K	SLP-00K000	Bucket Pull Arm	2	2
17	SLP-K-7R	SLP-00K006	Pull Arm Tie Bar R.H.	1	1
	SLP-K-7L	SLP-00K007	Pull Arm Tie Bar L.H.	1	1
18	SLP-12-L1	SLP-12L100	Bucket 12'	1	1
	SLP-14-L1	SLP-14L100	Bucket 14'	1	1
	SLP-16-L1	SLP-16L100	Bucket 16'	1	1
	SLP-18-L1	SLP-18L100	Bucket 18'	1	1
19	SLP-L2R	SLP-00L200R	Bucket Sides R.H.	1	1
	SLP-L2L	SLP-00L200L	Bucket Sides L.H.	1	1
20	SLP-F	SLP-00F000	Center Cross Frame	1	1
21	SLP-M	SLP-MTB	Bucket Turnbuckle Assembly	2	2
22	SLP-H	SLP-00H000	Tire Axle	1	1
23	SLP-A2L	SLP-00A200L	Top Frame, Rear For 40' Units - L.H.	1	-
		SLP-30A200L	Top Frame, Rear For 30' Units - L.H.	-	1
24	SLP-A2R	SLP-00A200R	Top Frame, Rear For 40' Units - R.H.	1	-
		SLP-30A200R	Top Frame, Rear For 30' Units - R.H.	-	1
25	SLP-A4	SLP-00A400	Front Rod - 114"	2	2
26	SLP-ABO-1	GTB-12X96A	3/4" X 6" Turnbuckle Assembly	4	2
27	SLP-E	SLP-40G000	Rear Inside Frame- For 40' units Only	1	-
28	SLP-A5	SLP-00A500	Rear Rod - 126" - For 40' Units Only	2	-
29	SLP-A3	SLP-00A300	L.H. Thread Stub End	4	2
30	SLP-14-C1	SLP-14C100	Rear Cross Frame For 12' & 14' w/Bushings	1	1
		SLP-16C100	Rear Cross Frame For 16' & 18' w/Bushings	1	1
31	SLP-C2	UBNF14128S	Rear Frame 8" Square U-Bolt	2	2
32	SLP-B1	SLP-00B100	Rear Steel Wheel Frame	2	2
33	SLP-B2R	SLP-00B200R	Scraper Blade Arm R.H.	3	3
	SLP-B2L	SLP-00B200L	Scraper Blade Arm L.H.	3	3
34	SLP-B2-3	SLP-00B203	Scraper Blade - Rear	2	2
35	SLP-ABO-2	UBNC05X22P	5/16" X 1-3/8" U-Bolts	2	1
36		CSNC516048	1" X 3" Gr.5 NC Cap Screw	2	2
37		CSNC516064	1" X 4" Gr.5 NC Cap Screw	2	2
38		CSNC820072	1-1/4" X 4-1/2" Gr.8 NC Cap Screw	4	4
39		LWASHER-16	1" Lock Washer	4	4
40		LWASHER-20	1-1/4" Lock Washer	4	4
41		HXNUT-16NC	1" NC Hex Nut	4	4
42		HXNUT-20NC	1-1/4" NC Hex Nut	4	4

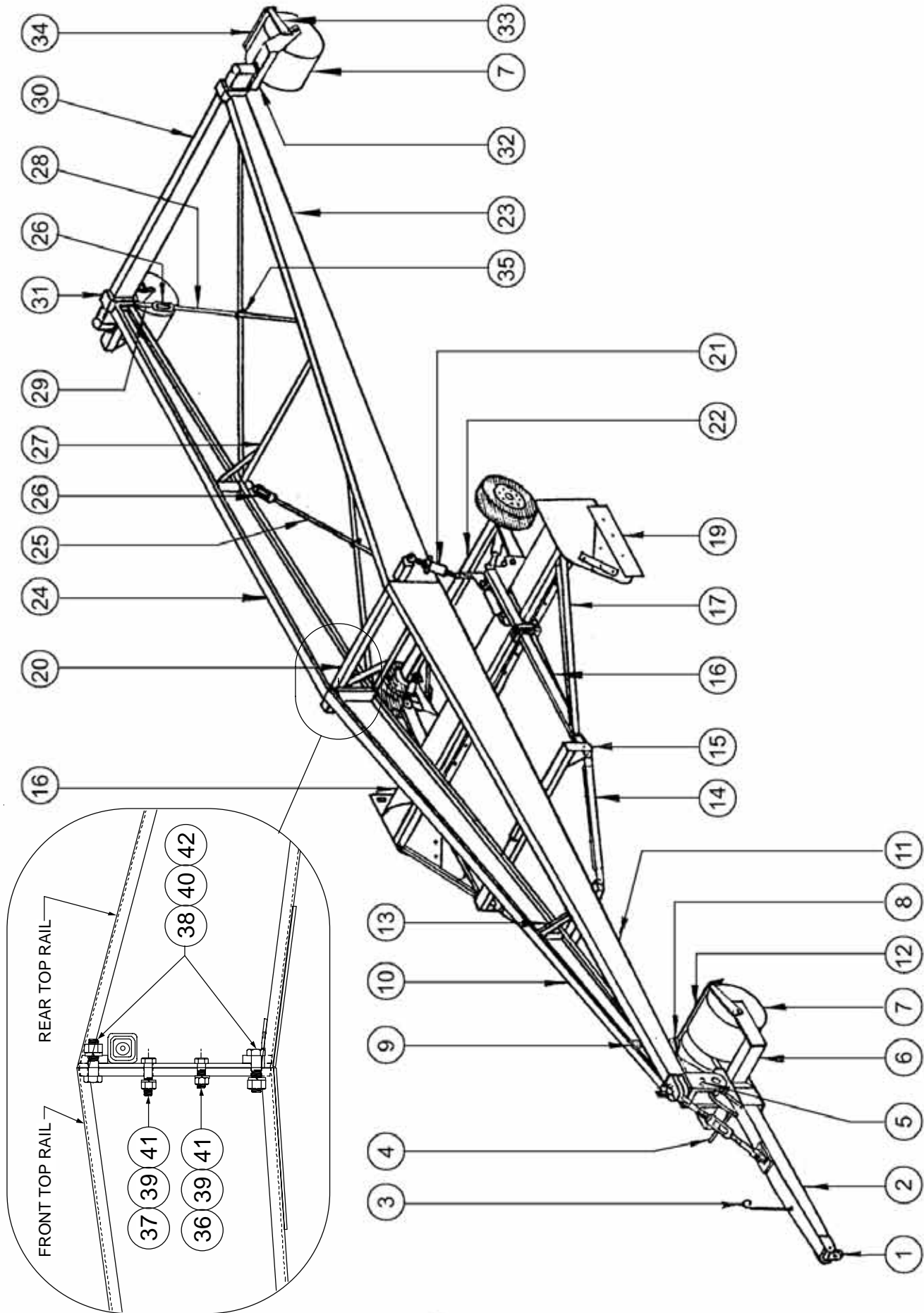



Item #	Old Part #	New Part #	Description	Q-ty
1	SLP-14L	SLP-12L100	Bucket 12'	1
		SLP-14L100	Bucket 14'	1
		SLP-16L100	Bucket 16'	1
		SLP-18L100	Bucket 18'	1
2	SLP-K	SLP-00K000L	Bucket Pull Arm Left	1
		SLP-00K000R	Bucket Pull Arm Right	1
3	SLP-K-7R	SLP-12K007R	Bucket Pull Arm For 12' Bucket Right	1
		SLP-14K007R	Bucket Pull Arm For 14' Bucket Right	1
		SLP-16K007R	Bucket Pull Arm For 16' Bucket Right	1
		SLP-18K007R	Bucket Pull Arm For 18' Bucket Right	1
4	SLP-K-7L	SLP-12K007L	Bucket Pull Arm For 12' Bucket Left	1
		SLP-14K007L	Bucket Pull Arm For 14' Bucket Left	1
		SLP-16K007L	Bucket Pull Arm For 16' Bucket Left	1
		SLP-18K007L	Bucket Pull Arm For 18' Bucket Left	1
5	SLP-J1	SLP-00J100	Cross Brace (Top Frame To Bucket)	1
6	SLP-L2R	SLP-00L200R	Bucket Side Right	1
7	SLP-L2L	SLP-00L200L	Bucket Side Left	1
8	SLP-L2-4	SLP-00L204	Bucket Side Adjustable Blade	2
9	SLP-12-L1-23	SLP-12L123	3/8" X 4" Single Beveled Blade 12'	1
	SLP-14-L1-23	SLP-14L123	3/8" X 4" Single Beveled Blade 14'	1
	SLP-16-L1-23	SLP-16L123	3/8" X 4" Single Beveled Blade 16'	1
	SLP-18-L1-23	SLP-18L123	3/8" X 4" Single Beveled Blade 18'	1
10	SLP-12-L1-24	SLP-12L124	1/2" X 6" Double Beveled Blade 12'	1
	SLP-14-L1-24	SLP-14L124	1/2" X 6" Double Beveled Blade 14'	1
	SLP-16-L1-24	SLP-16L124	1/2" X 6" Double Beveled Blade 16'	1
	SLP-18-L1-24	SLP-18L124	1/2" X 6" Double Beveled Blade 18'	1
11	SLP-12-L1-25	SLP-12L125	1/2" X 6" Blade Shim 12'	1
	SLP-14-L1-25	SLP-14L125	1/2" X 6" Blade Shim 14'	1
	SLP-16-L1-25	SLP-16L125	1/2" X 6" Blade Shim 16'	1
	SLP-18-L1-25	SLP-18L125	1/2" X 6" Blade Shim 18'	1
12		PBNC-10028	5/8" X 1-3/4" Plow Bolt	varies
13		LWASHER-10	5/8" Lock Washer	varies
14		HXNUT-10NC	5/8" Hex Nut	varies
3/8"x 4" REPLACEMENT KIT		SLP-BK3812	3/8" X 4" Blade Kit 12' (includes items 9 for 12',12,13,14)	
		SLP-BK3814	3/8" X 4" Blade Kit 14' (includes items 9 for 14',12,13,14)	
		SLP-BK3816	3/8" X 4" Blade Kit 16' (includes items 9 for 16',12,13,14)	
		SLP-BK3818	3/8" X 4" Blade Kit 18' (includes items 9 for 18',12,13,14)	
1/2"x 6" REPLACEMENT KIT		SLP-BK5012	1/2" X 6" Blade Kit 12'(includes items 10 for 12',12,13,14)	
		SLP-BK5014	1/2" X 6" Blade Kit 14'(includes items 10 for 14',12,13,14)	
		SLP-BK5016	1/2" X 6" Blade Kit 16'(includes items 10 for 16',12,13,14)	
		SLP-BK5018	1/2" X 6" Blade Kit 18'(includes items 10 for 18',12,13,14)	

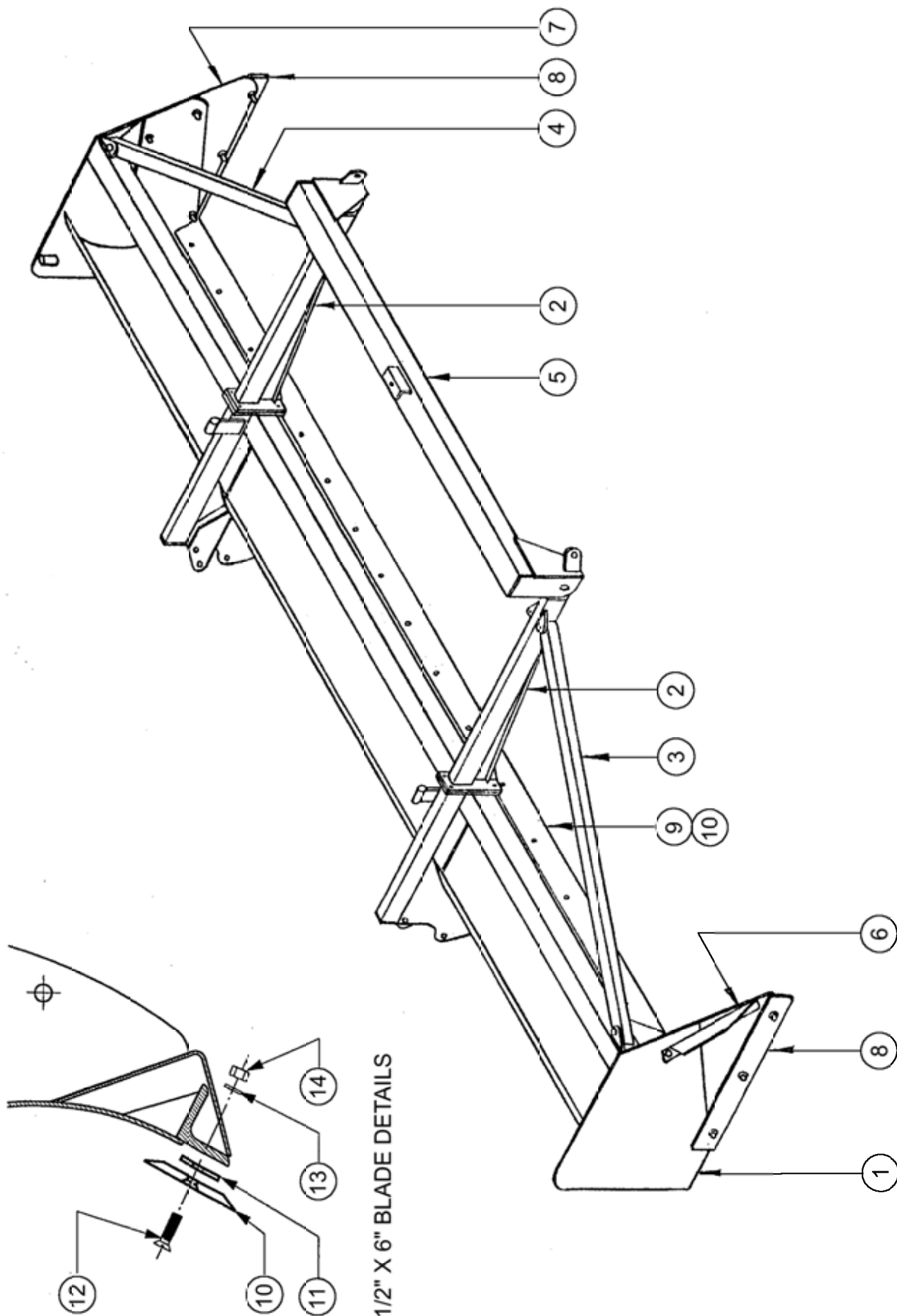

1/2" X 6" BLADE DETAILS



Item #	Old Part #	New Part #	Description	Q-ty Typ	Varied Qty & Lengths				
					All Units	12' Unit	14' Unit	16' Unit	18' Unit
1	SLP-12L1	SLP-12L100	Bucket 12'	1	144"				
	SLP-14L1	SLP-14L100	Bucket 14'	1		168"			
	SLP-16L1	SLP-16L100	Bucket 16'	1			192"		216"
	SLP-18L1	SLP-18L100	Bucket 18'	1					
2	SLP-12-L1-23	SLP-12L123	3/8" X 4" Single Beveled Blade 12'	1	143-1/2"				
	SLP-14-L1-23	SLP-14L123	3/8" X 4" Single Beveled Blade 14'	1		167-1/2"			215-1/2"
	SLP-16-L1-23	SLP-16L123	3/8" X 4" Single Beveled Blade 16'	1			191-1/2"		
	SLP-18-L1-23	SLP-18L123	3/8" X 4" Single Beveled Blade 18'	1					
	SLP-12-L1-24	SLP-12L124	1/2" X 6" Double Beveled Blade 12'	1	143-1/2"				
	SLP-14-L1-24	SLP-14L124	1/2" X 6" Double Beveled Blade 14'	1		167-1/2"			215-1/2"
	SLP-16-L1-24	SLP-16L124	1/2" X 6" Double Beveled Blade 16'	1			191-1/2"		
	SLP-18-L1-24	SLP-18L124	1/2" X 6" Double Beveled Blade 18'	1					
3	SLP-K-7R	SLP-12K007R	Bucket Pull Arm For 12' Right	1	45-9/16"				
		SLP-14K007R	Bucket Pull Arm For 14' Right	1		52-5/16"			
		SLP-16K007R	Bucket Pull Arm For 16' Right	1			61-13/16"		71-1/2"
		SLP-18K007R	Bucket Pull Arm For 18' Right	1					
4	SLP-K-7L	SLP-12K007L	Bucket Pull Arm For 12' Left	1	45-9/16"				
		SLP-14K007L	Bucket Pull Arm For 14' Left	1		52-5/16"			
		SLP-16K007L	Bucket Pull Arm For 16' Left	1			61-13/16"		71-1/2"
		SLP-18K007L	Bucket Pull Arm For 18' Left	1					
5	SLP-J2R	SLP-00J200R	Pull Brace Right	1					
6	SLP-J2L	SLP-00J200L	Pull Brace Left	1					
7	SLP-J1	SLP-00J100	Cross Brace (Top Frame To Bucket)	1					
8	SLP-K-L	SLP-00K000L	Bucket Pull Arm Left	1					
	SLP-K-R	SLP-00K000R	Bucket Pull Arm Right	1					
9	SLP-L2R	SLP-00L200R	Bucket Side Right	1					
10	SLP-L2L	SLP-00L200L	Bucket Side Left	1					
11	SLP-L2-4	SLP-00L204	Bucket Side Adjustable Blade	2					
12		PBNC-10028	5/8" X 1 3/4" Plow Bolt	16		(15)	(17)		(19)
13		CSNC510032	5/8" X 2" Gr.5 Z/P Bolts	12					
14		CSNC512032	3/4" X 2" Gr.5 Z/P Bolts	2					
15		CSNC516072	1" X 4 1/2" Gr.5 Z/P Bolts	6					
16		FWASHER-10	5/8" Flat Washer	16		(15)	(17)		(19)
17		FWASHER-10	5/8" Flat Washer	16		(15)	(17)		(19)
18		LWASHER-10	5/8" Lock Washer	12		(15)	(17)		(19)
19		LWASHER-10	5/8" Lock Washer	12		(15)	(17)		(19)
20		LWASHER-12	3/4" Lock Washer	16					
21		HXNUT-10NC	5/8" Hex Nuts	12					
22		HXNUT-10NC	5/8" Hex Nuts	2					
23		HXNUT-12NC	3/4" Hex Nuts	2					
24		NYNUT-16NC	1" Lock Nuts	2					
25		GPN-16X040	1" X 2 1/2" Clevis Pin	2					
		GPN-040LYN	1/4" X 1 3/4" Lynch Pin	2					

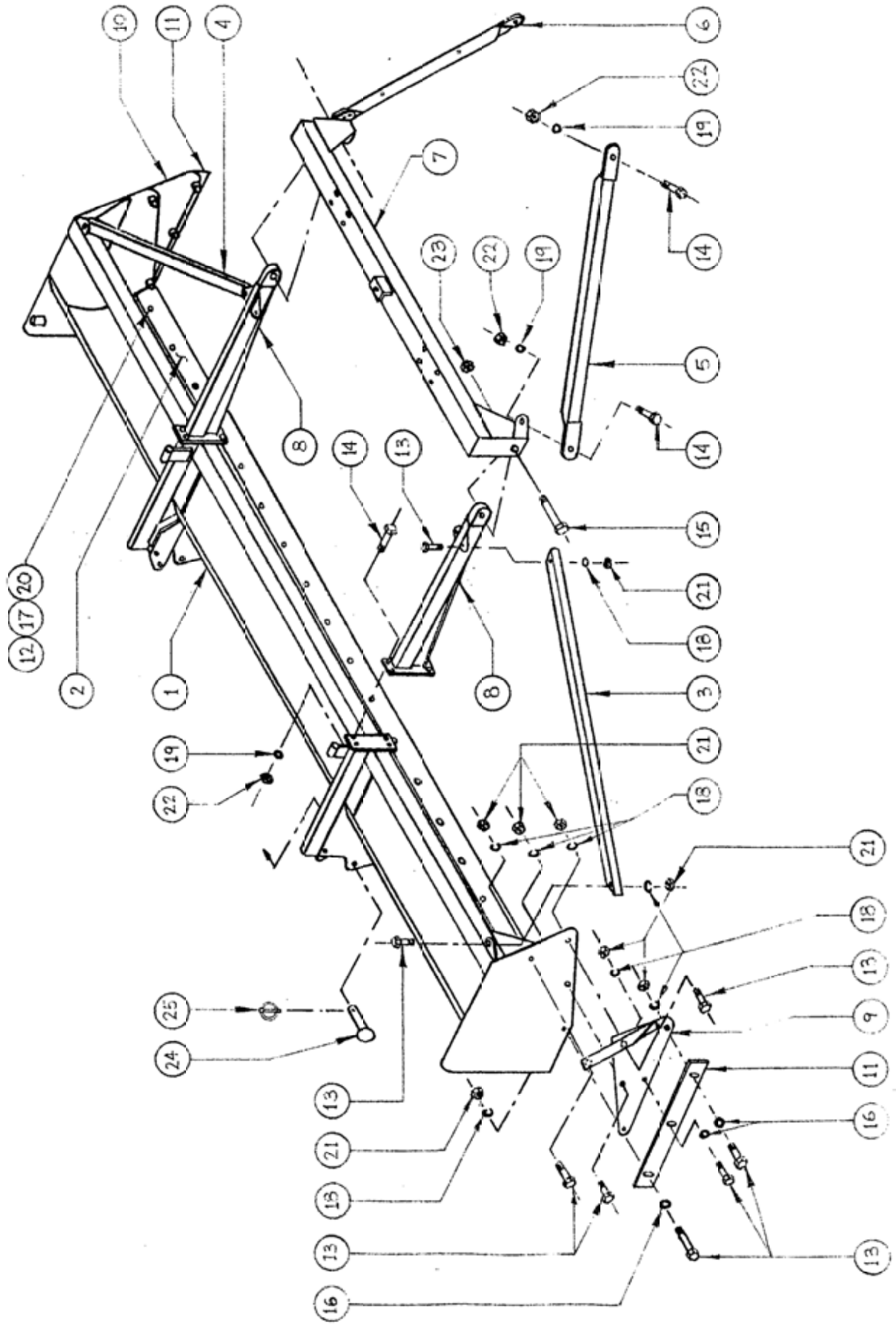



Item #	Old Part #	New Part #	Description	Q-ty
1	SLP-M4	SLP-00M400	Bucket Linkage Adjustment Rod	2
2	SLP-M-6	SLP-00M600	Bucket Linkage Straight Link	2
3	SLP-M-5	SLP-00M501	Bucket Linkage T-Bar Link	2
4	SLP-M2	SLP-00M200	Bucket Linkage Turnbuckle Bottom	2
5	SLP-M3	GTB-00A002	Turnbuckle Casting Machined	2
6	SLP-M1	SLP-00M100	Bucket Linkage Turnbuckle Top	2
7	SLP-M1-4	SLP-00M104	Turnbuckle End Plate	2
8	SLP-M1-5	SLP-00M105	Turnbuckle Crank Rod	2
9		CSNC516048	1" X 3" Gr.5 Z/P Bolt	4
10		SLP-00M900	1" X 6" Gr.5 Z/P Bolt with zerk hole	2
11		SLP-00M800	1" X 3-1/2" Gr.5 Z/P Bolt with zerk hole	2
12		CSNC508024	1/2" X 1-1/2" Gr.5 Z/P Bolt	2
13		GMB-ZERKTH	Threaded Grease Zerks	2
14		GMB-ZERKDT	Pressed-in (Drive Type) Zerk	6
15		LWASHER-16	1" Lock Washer	2
16		LWASHER-08	1/2" Lock Washer	2
17		HXNUT-16NC	1" Z/P Hex Nut	2
18		HXNUTJ16NC	1" Jam Nut	4
19		NYNUT-16NC	1" Nylon Lock Nut	6
		SLP-MTB	Bucket Turnbuckle Assembly Kit (Includes Items 4, 5, 6, 8, 13, 14)	

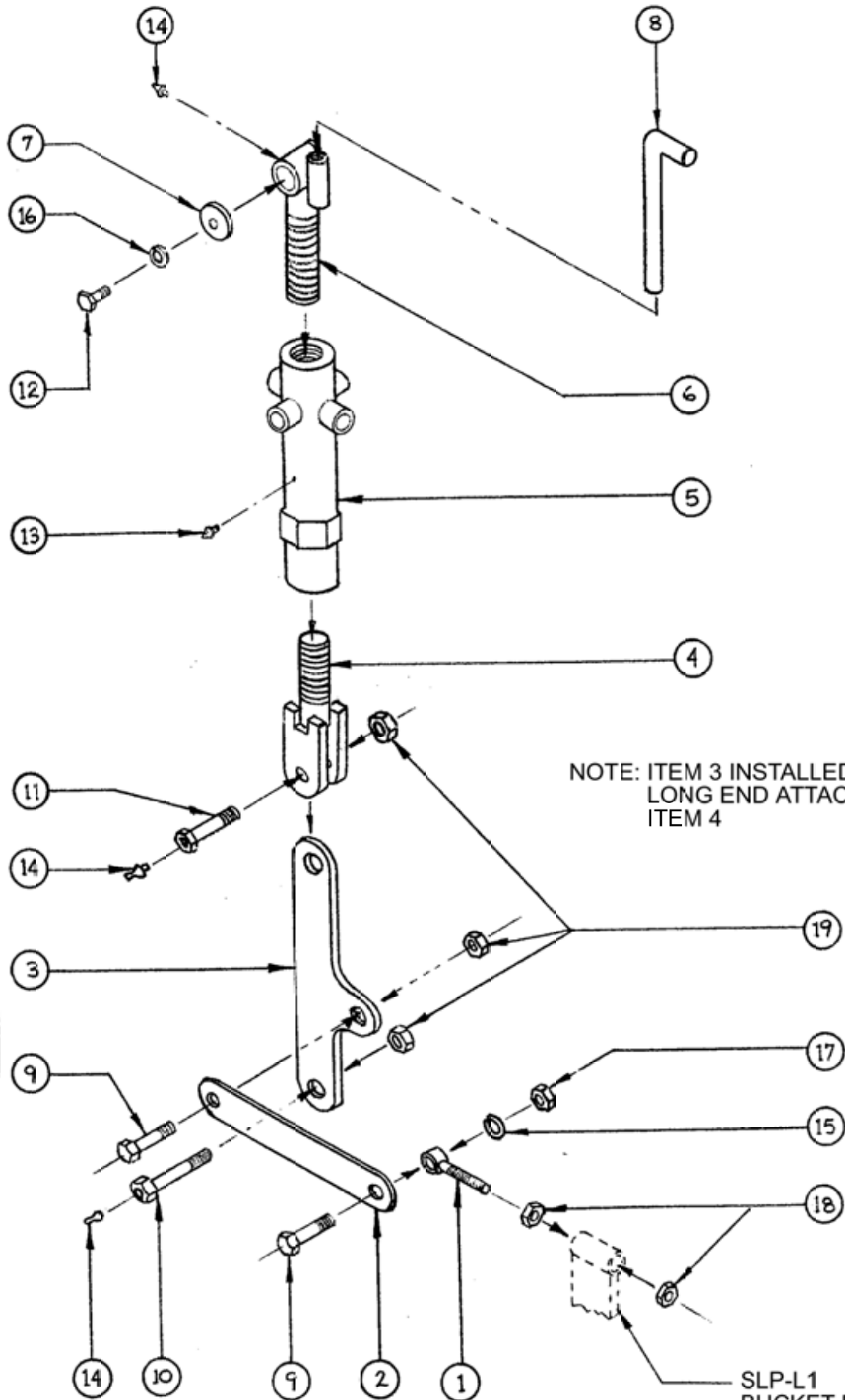



Item #	Old Part #	New Part #	Description	Q-ty
1	SLP-Q2	SLP-00Q200	Tongue Hitch	1
2	SLP-Q6	SLP-00Q700	Tongue Hitch Clevis Pin	1
3	SLP-Q5	GHD-HHOLD1	Hydraulic Line Support (Hose Holder)	1
4	SLP-Q1-18	SLP-00Q118	Tongue Lockout Bar	1
5	SLP-Q1	SLP-00Q100	Tongue	1
6	SLP-Q7	SLP-00Q800	Front Wheel Frame Bearing Clamp	1
7	SLP-P1	SLP-00P100	Front Steel Wheel Frame	1
8		CSNC512032	3/4" X 2-1/2" Gr.5 Z/P Bolt	6
9		FWASHER-12	3/4" Flat Washer	1
10		LWASHER-12	3/4" Lock Washer	6
11		HXNUT-12NC	3/4" Hex Nut	1
12		NYNUT-12NC	3/4" Nylon Lock Nut	1
13		CANUT-24NF	1-1/2" Nf Castle Nut	1
14		GPN-12X040	3/4" X 2-1/2" Clevis Pin	1
15		GPN-040LYN	1/4" X 1-3/4" Lynch Pin	2
16		GPN-04X40C	1/4" X 2-1/2" Cotter Pin	1
17		GMB-ZERKTH	Threaded Grease Zerk	1
18		GMB-ZERKTH	Threaded Grease Zerk	1
25	SLP-QBO-J	GJK-5KTW10	10", 5000# Jack Stand	1
27	SLP-A6BO-3	GBR-48TB01	Thrust Bearing	1
28	SLP-A6BO-1	GBR-47394S	Oil Seal	1
29	SLP-A6BO-4	GBR-4856GB	Housing Bushing	2
30	SLP-P1-14	SLP-00P114	1/4" Shaft Washer	1
31	SLP-A6-3	SLP-00P115	3/8" Bottom Washer	1
32	SLP-P1-10	SLP-00P300M	Bearing Housing Machined	1
33		SLP-00Q119	Pull Frame Bearing Shaft	1

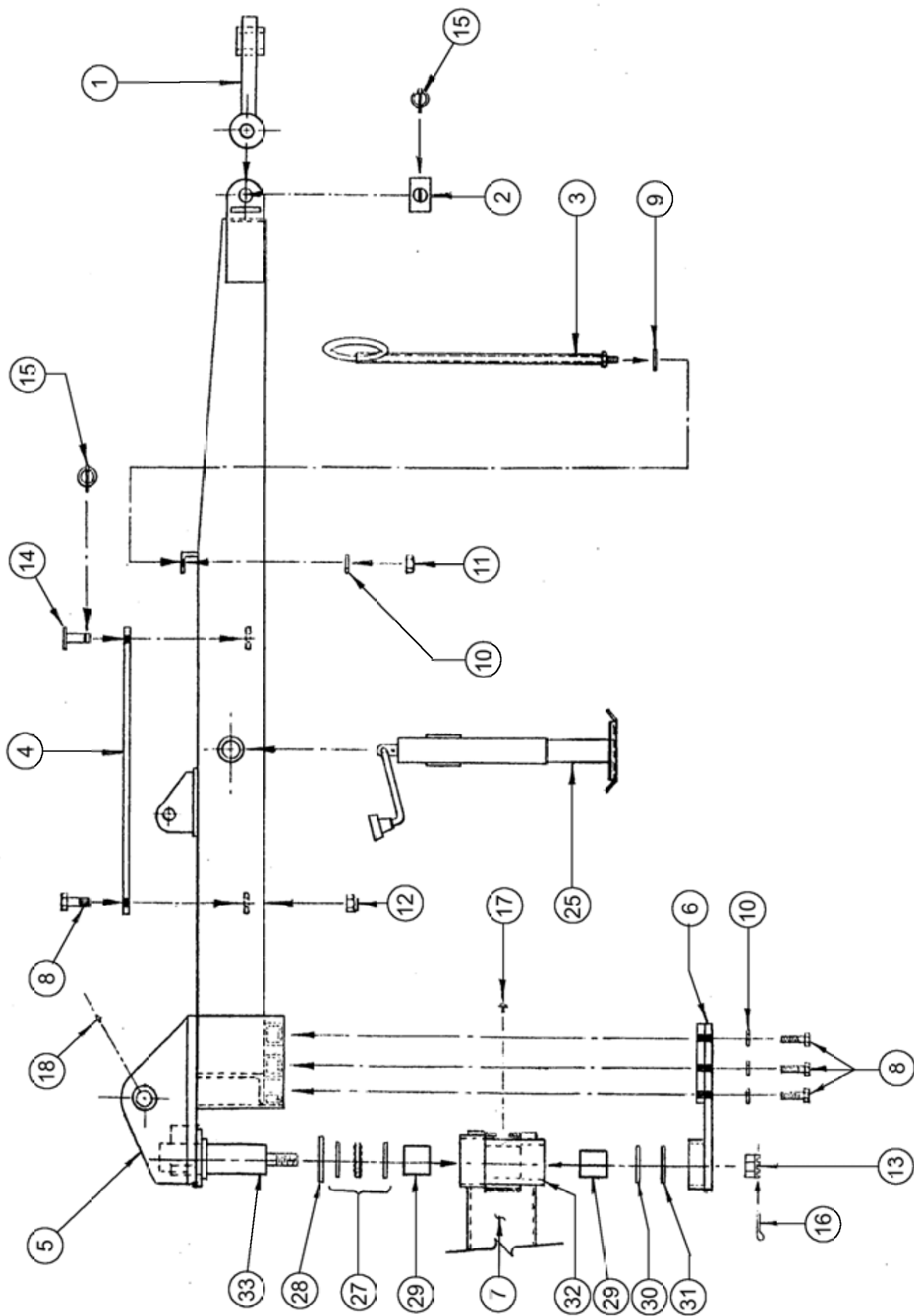



Item #	Old Part #	New Part #	Description	Q-ty
1	SLP-N	SLP-00N000	Main Frame Pivot Shaft Weldment	1
		SLP-00N001	Main Frame Pivot Shaft only	1
2	SLP-N-9	SLP-00N100	Main Frame Pivot Shaft Clevis Pin	1
3	SLP-A6BO-3	GBR-48TB01	Thrust Bearing	1
4	SLP-A6BO-1	GBR-47394S	Oil Seal	1
5	SLP-A6BO-4	GBR-4856GB	Housing Bushing	3
6	SLP-A6F	SLP-00A600F	Top Frame Front Bearing Housing	1
7	SLP-A6-3	SLP-00A603	3/8" Shaft Cap	1
8	SLP-A6BO-5	GBR-00GC01	Housing Dust (Grease) Cap	1
9		C-2A	7/8" NF Grade C Lock Nut	1
10		GMB-ZERKTH	Threaded Grease Zerk	1
11		CANUT-24NF	1-1/2" NF Castle Nut	1
12		GPN-04X40C	1/4" X 2-1/2" Cotter Pin	1
		SLP-00A6KFC	Front Bearing Housing Kit Complete (Includes all above items)	
		BC-100	Bearing Housing Half Clamp - welds to Main Frame (not shown)	

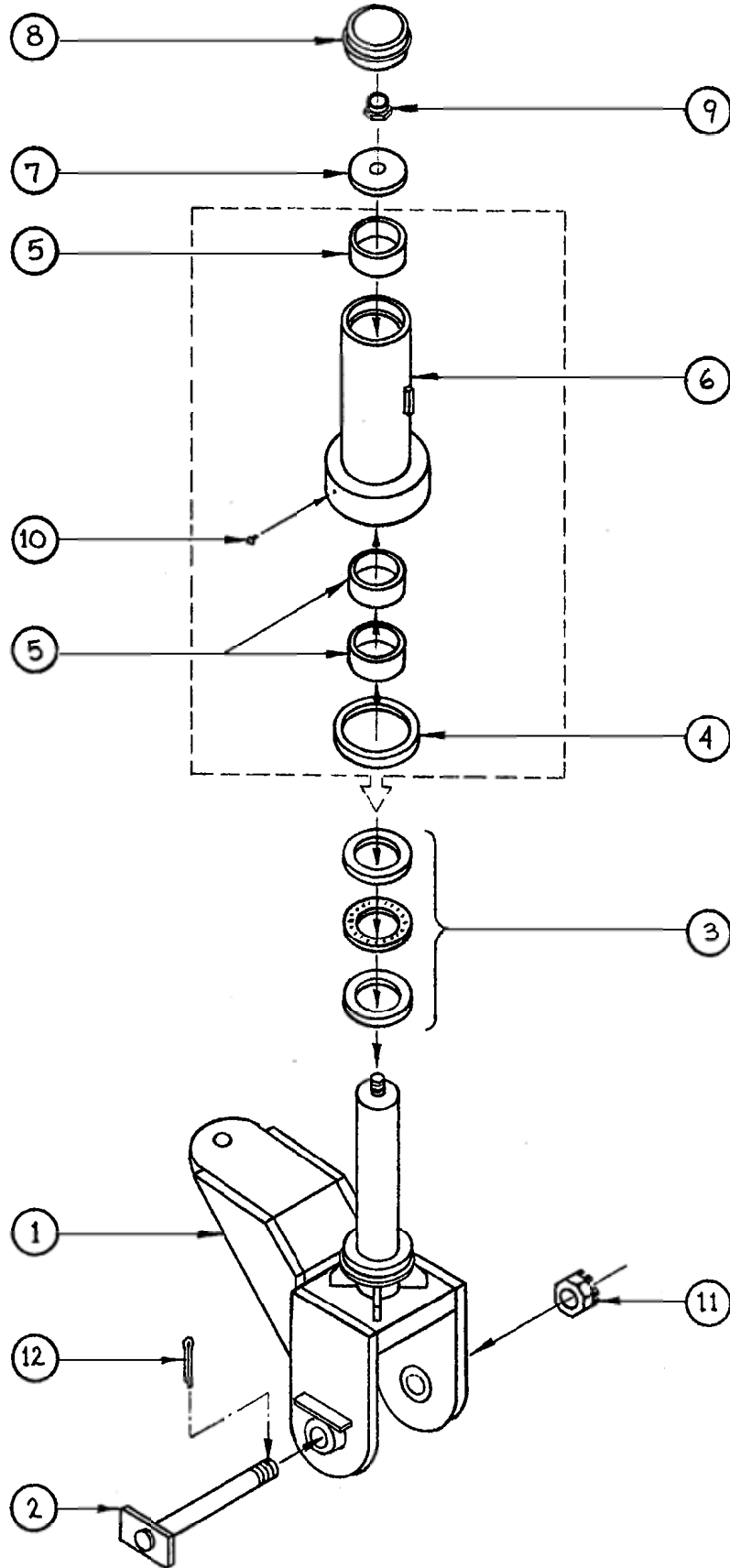



Item #	Old Part #		New Part #	Description	Q-ty
1	SLP-Q4BO-1	}	SLP-00Q300	Tri-Plane Front Turnbuckle Ass'y (sold as assembly only)	1
2	SLP-Q4-1				
3	SLP-Q4-2				
4			GPN-16X040	1" X 2-1/2" Clevis Pin	2
5			GPN-040LYN	1/4" Lynch Pin	2

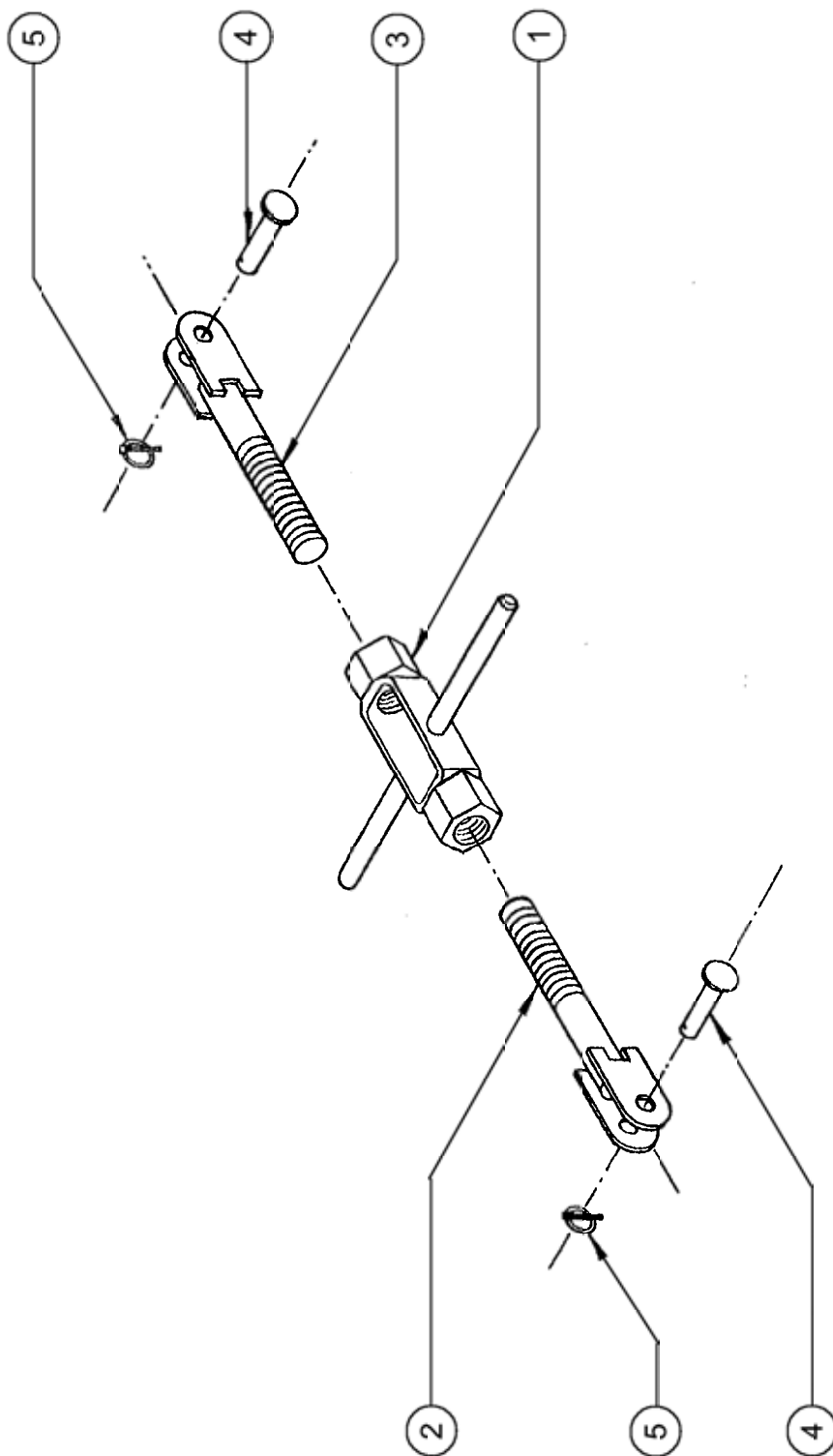



Item #	Old Part #	New Part #	Description	Q-ty
1	SLP-P1	SLP-00P100	Front Steel Wheel Frame	1
2	SLP-D	SLP-00D000	Steel Wheels	2
3	SLP-B2	SLP-00B200L	Scraper Blade Arm Left	1
		SLP-00B200R	Scraper Blade Arm Right	1
4	SLP-P1-9	SLP-00P200	Front Wheel Scraper Blade	1
5	SLP-DBO-1	TPP3152	1-11/16" Flange Bearings	4
6		CSNC508036	1/2" X 2-1/4" Gr.5 Z/P Bolts	16
7		CSNC508032	1/2" X 2" Gr.5 Z/P Bolts	4
8		CSNC508024	1/2" X 1-1/2" Gr.5 Z/P Bolts	2
9		HXNUT-08NC	1/2" Hex Nut	22
10		FWASHER-08	1/2" Flat Washer	2
11		LWASHER-08	1/2" Lock Washer	22

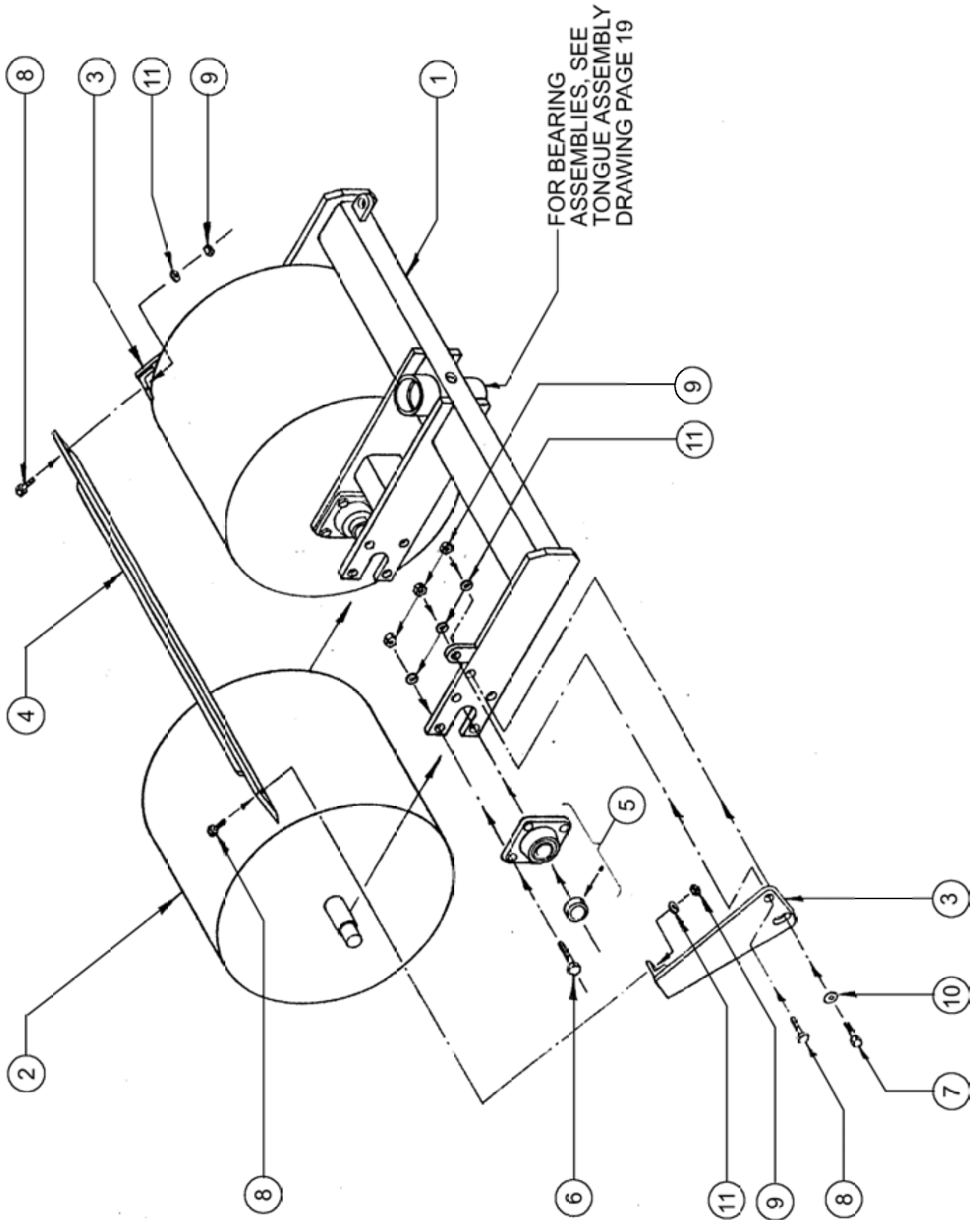



Item #	Old Part #	New Part #	Description	Q-ty
1	SLP-B1	SLP-00B100	Rear Steel Wheel Frame	2
2	SLP-D	SLP-00D000	Steel Wheels	2
3	SLP-B2	SLP-00B200L	Scraper Blade Arm Left	2
		SLP-00B200R	Scraper Blade Arm Right	2
4	SLP-B2-3	SLP-00B203	Scraper Blade	2
5	SLP-B3	SLP-00B300	Locking Arm	2
6	SLP-B3-4	SLP-00B304	Locking Arm Bearing Bushing	2
7	SLP-A6R	SLP-00A600R	Rear Frame Bearing Housing	2
8	SLP-A6-3	SLP-00A603	Shaft Cap	2
9		GMB-ZERKDT	Pressed In Grease Zerk	2
10	SLP-A6BO-4	GBR-4856GB	Housing Bushing	6
11	SLP-A6BO-3	GBR-48TB01	Thrust Bearing	2
12	SLP-A6BO-1	GBR-47394S	Oil Seal	2
13	SLP-B3BO-1	GBR-00CB01	Locking Arm Bearing (Centering Bearing)	2
14	SLP-BBO-S	GSR-CENT01	Locking Arm Spring (Centering Spring)	2
15	SLP-DBO-1	TPP3152	1-11/16" Flange Bearing	4
16	SLP-A6BO-5	GBR-00GC01	Housing Dust Cap	2
17		CSNC508016	1/2" X 1" Gr.5 Z/P Bolts	2
18		CSNC508024	1/2" X 1-1/2" Gr.5 Z/P Bolts	4
19		CSNC508032	1/2" X 2" Gr.5 Z/P Bolts	8
20		CSNC508036	1/2" X 2-1/4" Gr.5 Z/P Bolts	18
21		FWASHER-08	1/2" Flat Washer	10
22		NYNUT-14NFJ	7/8" Nf Nylon Lock Jam Nut	2
23		LWASHER-08	1/2" Lock Washer	30
24		HXNUT-08NC	1/2" Hex Nut	28
25		NYNUT-08NC	1/2" Nylon Lock Nut	2
26		GMB-ZERKTH	Threaded Grease Zerk	2
27		SLP-00N001	Pivot Shaft	2
28		SLP-00B105	Rear Frame Shaft Collar	2
		SLP-00A6KRP	Rear Frame Bearing Housing Kit Partial (Includes items: 7, 10, 11, 12, 26)	2
		SLP-00A6KRC	Rear Frame Bearing Housing Kit Complete (Includes items: 7, 8, 10, 11, 12, 16, 22, 26, 27, 28)	2

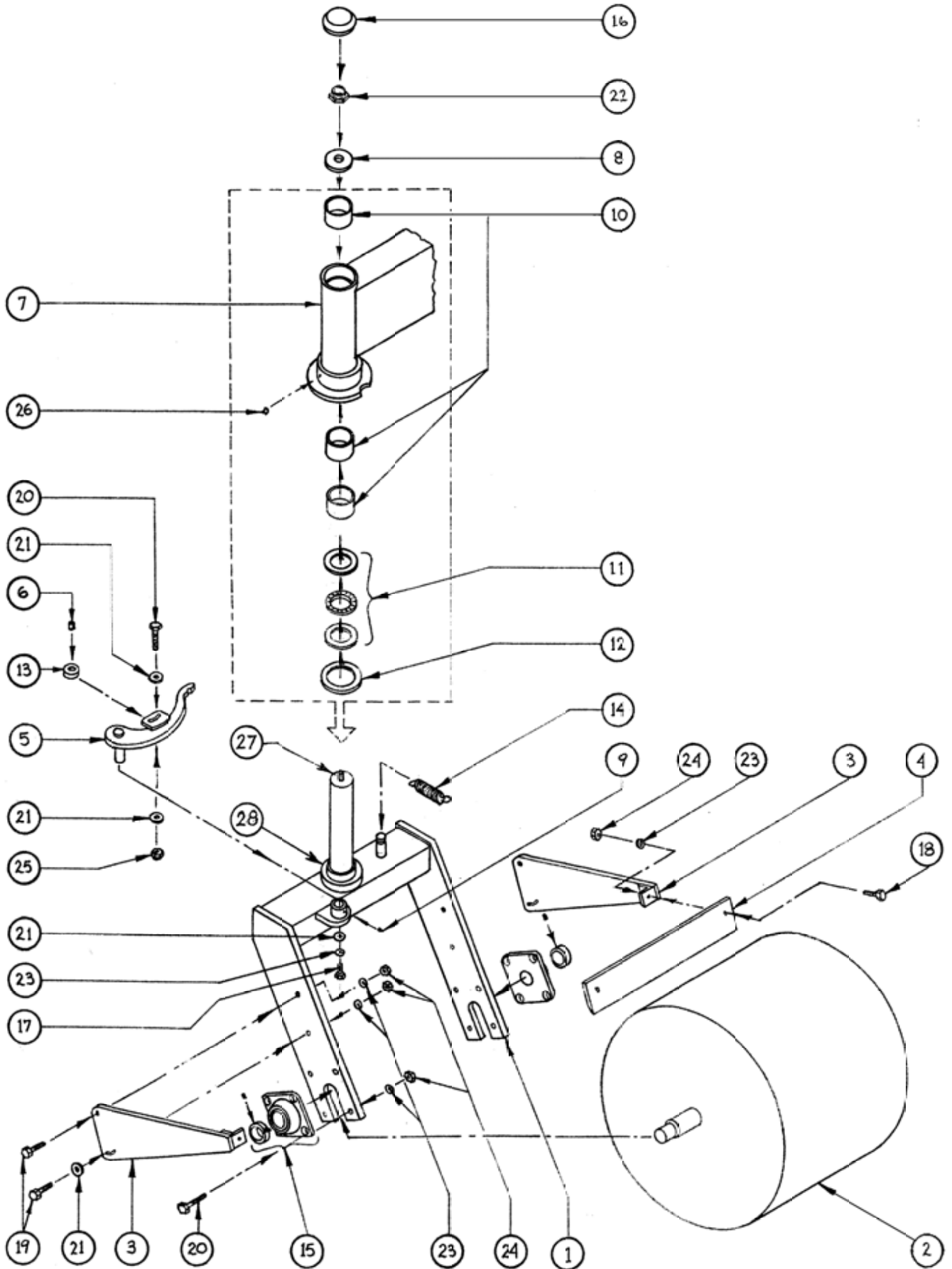



Item #	Old Part #	New Part #	Description	Q-ty
1	SLP-HBO-1	GHB-8X8GSL	Oil Seal For 8 On 8 Heavy Hub	2
2	SLP-HBO-2	GHB-8X8ICN	Inner Bearing Cone For 8 On 8 Heavy Hub	2
3	SLP-HBO-3	GHB-8X8IRC	Inner Bearing Race For 8 On 8 Heavy Hub	2
4	SLP-HBO-4	GHB-8X8HVY	Hub, 8 On 8 Heavy Complete (includes items 1, 2, 3, 5, 6, 7)	2
5	SLP-HBO-5	GHB-8X8ORC	Outer Bearing Race For 8 On 8 Heavy Hub	2
6	SLP-HBO-6	GHB-8X8OCN	Outer Bearing Cone For 8 On 8 Heavy Hub	2
7	SLP-HBO-7	GHB-8X8CAP	Dust Cap For 8 On 8 Heavy Hub	2
9	SLP-HBO-9	GWT-121614	12.5 X 16 14 Ply Tire with Wheel	2
11	SLP-HBO-11	WHB-09X018	Wheel Bolts For 8 On 8 Heavy Hub	16
12	SLP-HBO-12	GSP-14CANT	7/8" Castle Nut, Spindle	2
13	SLP-HBO-13	GSP-14SPWA	7/8" Flat Washer, Spindle	2
14	SLP-H	SLP-00H000	Tire Axle	1
15		SLP-00M800	1" X 3-1/2" Gr.5 Z/P Bolts with Zerk	2
16		NYNUT-16NC	1" Nylon Lock Nut	2
17		GMB-ZERKDT	Pressed-In Grease Zerk	2
18		GPN-04X28C	1/4" X 1-3/4" Cotter Pin	2
19		GSP-34248S	2-1/8" X 15-1/2" Single Ended Spindle	2
		SLP-00HKIT	Tri Plane Spindle Assembly Kit (includes items 12, 13, 18, 19)	



NOTE: INFLATE TIRES TO 30 PSI

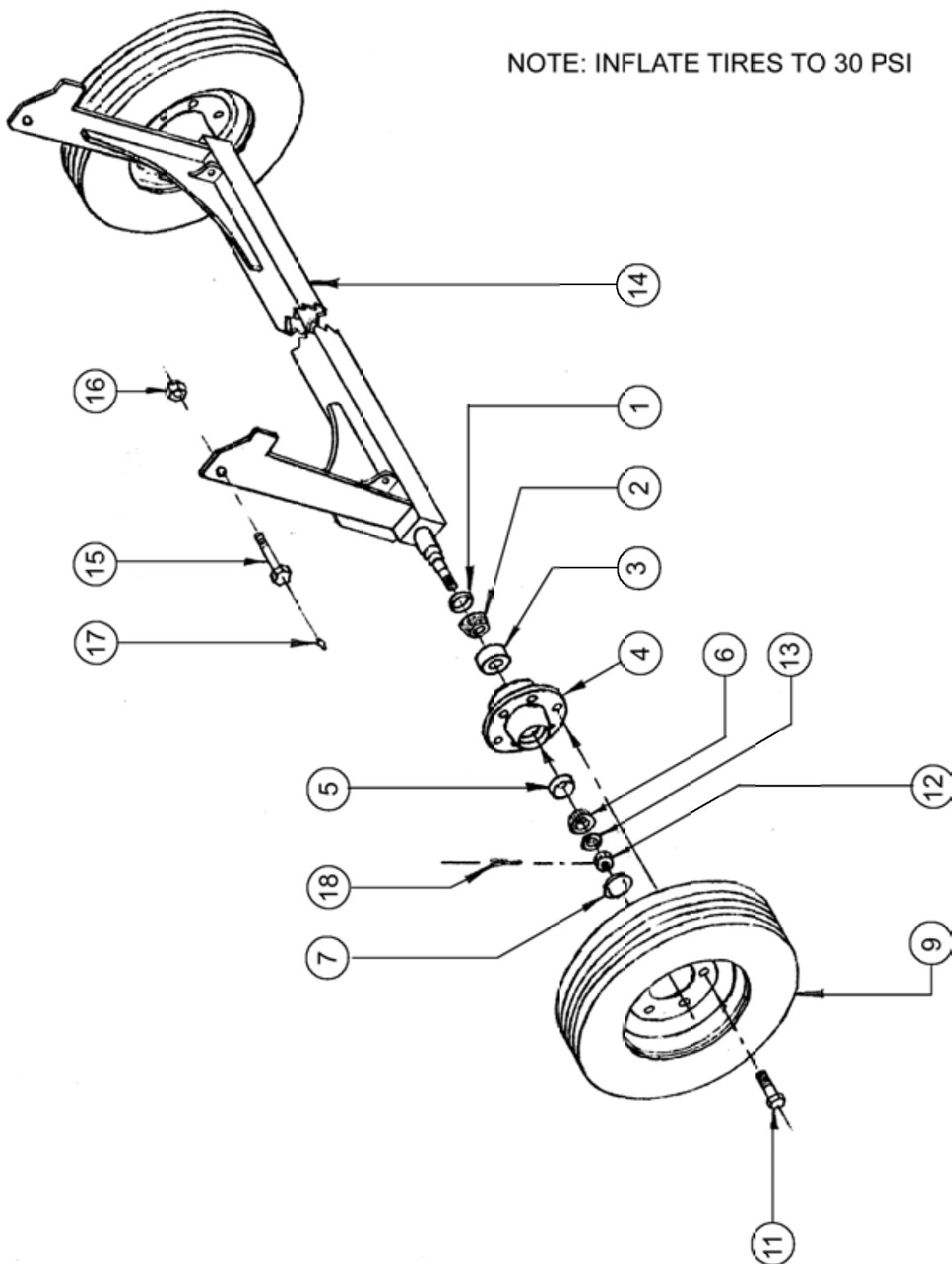



Item #	Old Part #	New Part #	Description	Q-ty
1	SLP-A10BO-1	F0828CAP	1/2" Pipe Plugs	2
2	SLP-A10BO-2	FFFPF0088C	1/2" Couplings	2
3	SLP-A10BO-HC	HYCONCLP01	Hose Clamp	5
4	SLP-A10-3	SLP-00Q901	1/2" X 252" Hydraulic Pipe	2
5	SLP-A10BO-3	VFLOWDIV01	1/2" Hydraulic Flow Control Valve	1
6	SLP-A10BO-4	FFPT080000	1/2" Pipe Tee	1
7	SLP-A10-4	SLP-00Q902	1/2" X 36" Hydraulic Pipe	4
8	SLP-A10BO-5	FFFPF9088C	1/2" X 90 Elbow	4
9	SLP-A10BO-HL 33	} HK SLP	Hydraulic Hose 1/2" X 33"	2
10	SLP-A10BO-HL 41		Hydraulic Hose 1/2" X 41"	2
11	SLP-A10BO-HC 3½X8	GHC-35080W	Hydraulic Cylinder 3-1/2" X 8" Welded	2
12	SLP-A10BO-6	GPN-1656HC	1" X 3-1/2" Hydraulic Cylinder Pins	4
13	SLP-A10BO-7	GPN-02CLIP	Hitch Pin Clip	8
14		CSNC505040	5/16" X 2-1/2" Gr.5 Z/P Bolts	5
15		LWASHER-05	5/16" Lock Washers	5
16		HXNUT-05NC	5/16" Hex Nuts	5
17		FMPFPX88	8MP-8FPX Coupling	2
18		FMPFPX9088	8MP-8FPX Elbow	2

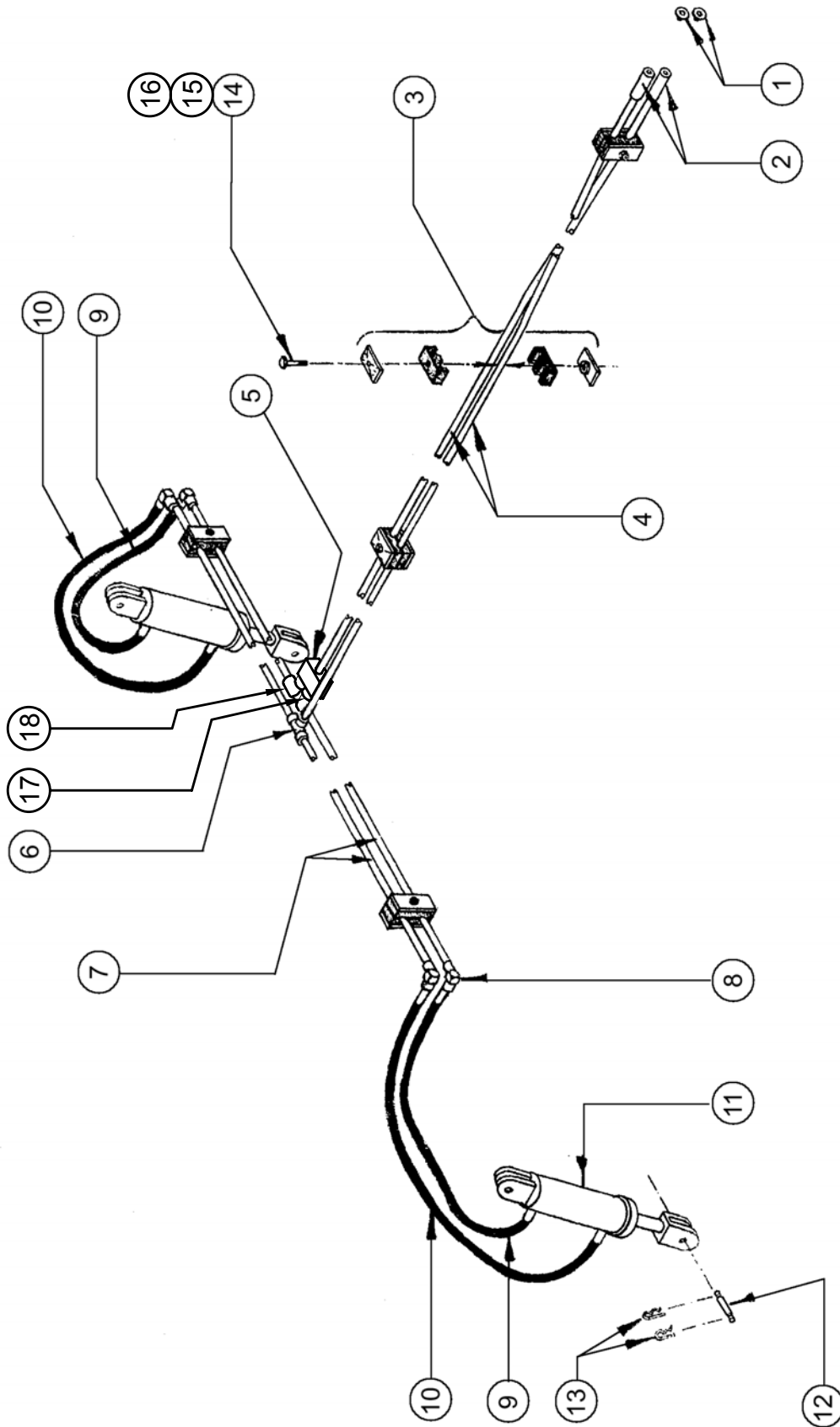



Item #	Old Part #	New Part #	Description	Q-ty
1	SLP-A1OBO-1	F0828CAP	1/2" Pipe Plugs	2
2	SLP-A1OBO-2	FFPFP0088C	1/2" Couplings	2
3	SLP-A1OBO-HC	HYCONCLP01	Hose Clamp	5
4	SLP-A1O-3	SLP-00Q901	1/2" X 252" Hydraulic Pipe	2
5	SLP-A10BO-3	VFLOWDIV01	1/2" Hyd. Flow Control Valve	1
6	SLP-A10BO-4	FFPT080000	1/2" Pipe Tee	1
7	SLP-A1O-4	SLP-00Q902	1/2" X 36" Hydraulic Pipe	4
8	SLP-A10BO-5	FFPFP9088C	1/2" X 90 Elbow	4
9	SLP-A1OBO-HL 28	} HK HBO	Hydraulic Hose 1/2" X 28"	2
10	SLP-A1OBO-HL 36		Hydraulic Hose 1/2" X 36"	2
11	SLP-A1OBO-HC 3 X 8	GHC-30080T	Hydraulic Cylinder 3" X 8" Tie Rod	2
12	SLP-M-7	SLP-00M700	Lockout Pins	4
13		GPN-04X40C	1/4" X 2-1/2" Cotter Pins	8
14		CSNC505040	5/16" X 2-1/2" Gr.5 Z/P Bolts	3
15		CSNC505072	5/16" X 4-1/2" Gr.5 Z/P Bolts	2
16		HXNUT-05NC	5/16" Hex Nuts	5
17		LWASHER-05	5/16" Lock Washers	5
18		GPN-040LYN	1/4" Lynch Pins	4
19		FMPFPX88	8MP-8FPX Straight Coupling	2
20		FMPFPX9088	8MP-8FPX Elbow	2
		SLP HBO	Hydraulic Bucket Kit (includes all above items)	

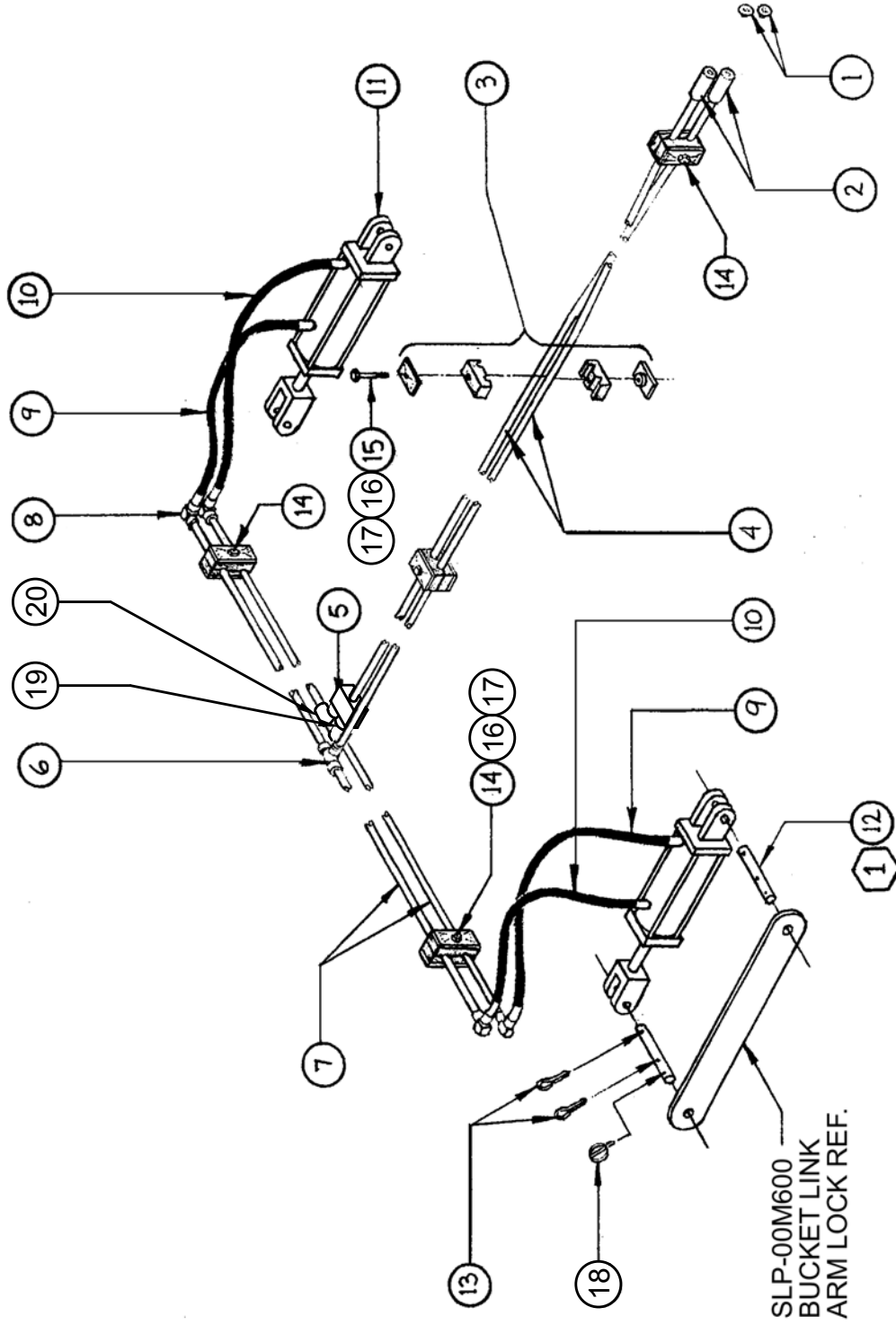

SLP-00M600
BUCKET LINK
ARM LOCK REF.

1 REPLACES 1" N.C. X 3" BOLT W/
NYLON LOCK NUT



Item #	Old Part #	New Part #	Description	Q-ty
1	SLP-P2BO-1	GHB-6X6GSL	Oil Seal For 6 on 6 Standard Hub	4
2	SLP-P2BO-2	GHB-6X6ICN	Inner Bearing Cone For 6 on 6 Std Hub	4
3	SLP-P2BO-3	GHB-6X6IRC	Inner Bearing Race For 6 on 6 Std Hub	4
4	SLP-P2BO-4	GHB-6X6STD	Hub, 6 on 6 Standard Complete – Kit (includes items 1, 2, 3, 4, 5, 6)	4
5	SLP-P2BO-5	GHB-6X6ORC	Outer Bearing Race For 6 on 6 Std Hub	4
6	SLP-P2BO-6	GHB-6X6OCN	Outer Bearing Cone For 6 on 6 Std Hub	4
7	SLP-P2BO-7	FWASHER-14	7/8" Flat Washer	4
8	SLP-P2BO-8	CANUT-14NC	7/8" Castle Nut	4
9	SLP-P2BO-9	GHB-6X6CAP	Dust Cap For 6 on 6 Std. Hub	4
10	SLP-P2BO-10	GWT-156LBH	15 X 6 Wheel (6 on 6)- Optional	4
11	SLP-P2BO-11	GWT-951508	9.5 X 15 8 Ply Tire W/Wheel	4
12	SLP-P2BO-12	WHB-08X016	Wheel Bolts For 6 on 6 Std. Hub	24
13	SLP-P2	SLP-00P400	Quad Tire Axle Frame	1
14		GPN-04X28C	1/4" X 1-3/4" Cotter Pin	4
15	SLP-P2-06	GSP-32324D	2" X 20-1/4" Double Ended Spindle	2
16	SLP-P2-03	GGU-08X25S	General Spindle Gusset	4
		GSP-32324DK	2" X 20-1/4" Double Ended Spindle Kit (includes items 7, 8, 14, 15, 16)	

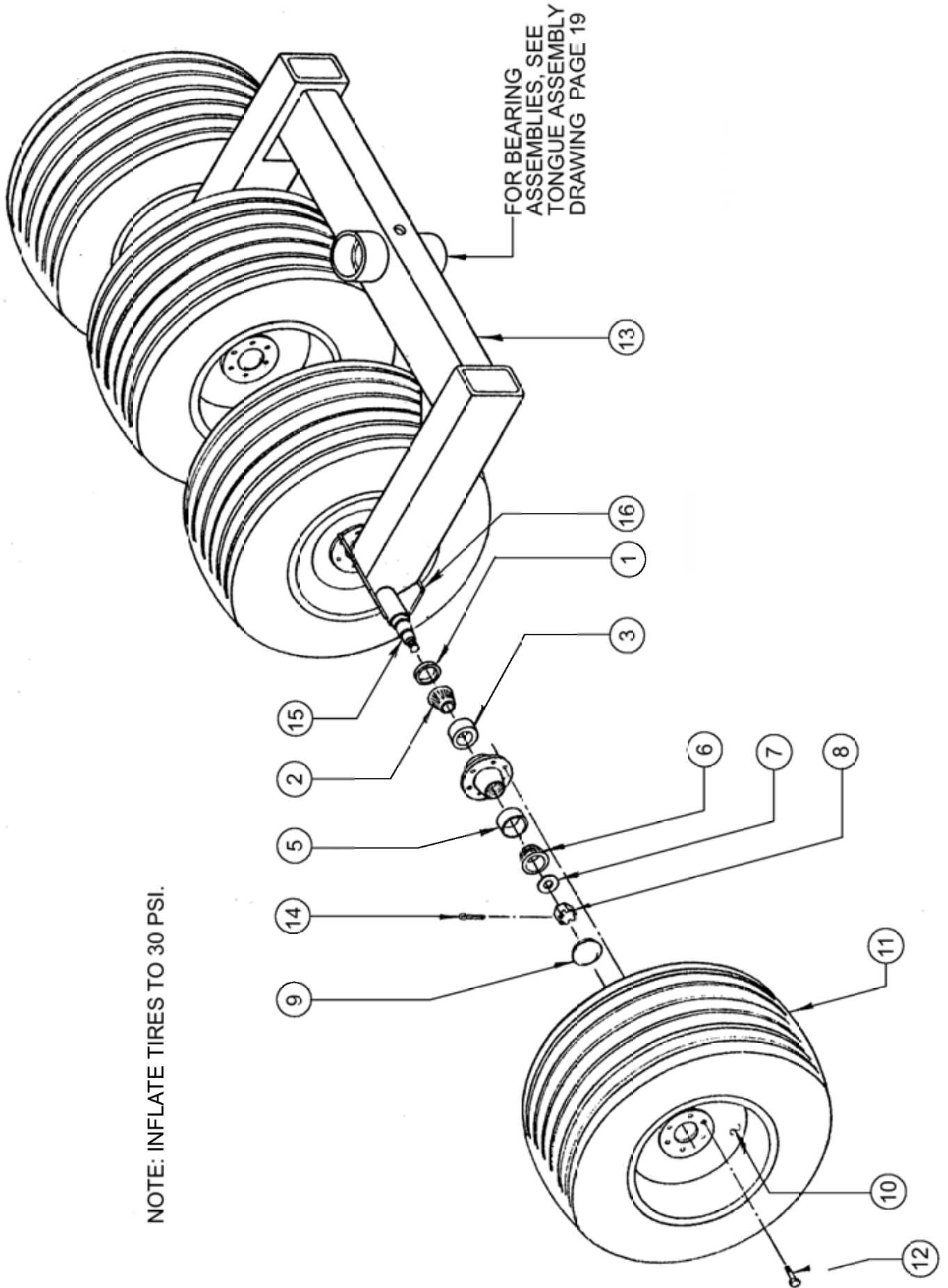



THE FOLLOWING TOOLS ARE NEEDED:

- Truck with lifting boom, overhead hoist or forklift with 2000 pound lifting capacity.
- A 24" adjustable wrench or large pipe wrench.
- One 6" and two 12" adjustable wrenches.
- Socket wrench with 15/16" and 1-1/2" sockets.
- Heavy duty pliers.
- A heavy duty 12" screwdriver.
- A 14" tapered drift punch.
- A pry bar.
- A medium size ballpeen hammer.
- A ten-pound sledge hammer.
- Grease gun.

PROCEDURE:

1. Place the main frame with the front bearing clamp toward the front on level ground. Raise front and put wooden block about 4" high underneath it. Place the left rear main frame butt to butt with the left front main frame. Join together. Line up the mating holes and install (2) 1-1/4" NC x 4-1/2" Gr.8 bolts with lock washers and hex nuts and (1) 5/8" NC x 2" bolt with lock washer and hex nut in the hole near the bottom 1-1/4" NC bolt. Do not tighten.
2. Hoist the center cross frame (see drawing on page 11 – item # 20) up with sling or chain attached to the 3" x 3" tube so that the cross frame is parallel to the ground and oriented to the square hole in the upper middle section of the left main frame. Line up the mating holes on the main frame and install (2) 1-1/4" NC x 4-1/2" Gr.8 bolts with lock washers and hex nuts and (1) 5/8" NC x 2" bolt with lock washer and hex nut in the hole near the bottom 1-1/4" NC bolt. Make sure the cross frame is positioned so that the attaching bracket on the bottom side of the 3" x 3" square tube is flush on the side facing the forward end of the machine. Now slide the end of the square tube through the square hole in the frame until the two attaching holes match up. Install one 1" x 4" bolt with lock washer and hex nut and one 1" x 3" bolt with lock washer and hex nuts. Do not tighten. Keep center cross frame suspended.
3. Place the right rear main frame butt to butt with the right front main frame. Join together. Be sure that the end of the center cross frame square tube goes through the square hole in the right side of the main frame until the two attaching holes match up. Install one 1" x 4" bolt with lock washer and hex nut and one 1" x 3" bolt with lock washer and hex nuts. . Line up the mating holes on the main frame and install (2) 1-1/4" NC x 4-1/2" Gr.8 bolts with lock washers and hex nuts and (1) 5/8" NC x 2" bolt with lock washer and hex nut in the hole near the bottom 1-1/4" NC bolt. Do not tighten.
4. Install rear inside frame (see drawing on page 11 – item # 27). Use (4) 5/8" NC x 2" bolts, lock washers and hex nuts. Tighten all bolts securely.
5. Lift up front of the machine. Open up front clamp BC-200 and install the front steel wheel frame and main frame pivot shaft assembly (with bearing housing, thrust bearing, inner races, pin bearings,

shaft cap, oil seal & dust cap) into the bearing clamp opening on the front end of the right and left main frames. Join the bearing clamps together and line up the six mating holes. Install six 3/4" NC x 2" bolts, lock washers and hex nuts. Tighten up enough to hold bearing housing in place.

6. Install front pivot shaft lockout (with two slotted holes). See drawing on page 11 - item # 8 Use two 3/4" NC x 2" bolts, flat washers, lock washers and hex nuts. Tighten securely. Place lock pin in position.
7. Position rear cross frame against the mounting plates on the rear end of the main frame. Guide stops on the rear cross frame should be next to mounting plates on the main frame. Adjust main frame height (if necessary) so that the two 8" U-bolts (see drawing on page 11 – item # 31) can be placed around the rear cross frame tube and inserted through the four mating holes in the end plate of the rear main frame. Install four 7/8" NF hex nuts and lock washers. Make necessary sideways adjustments and tighten securely.
8. Attach rear steel wheel pivot frames to the rear cross frame. Use 1-1/2" Rear Hinge Pins with slotted hex nuts and cotter pins. Mount steel wheels to the pivot frames (see page 27 for details).
9. Put bucket beside main frame with pull arms facing forward. Place piece of pipe underneath bucket. Push bucket from one end under main frame until bucket arms align with bucket cross brace. Fasten with 1" x 4" bolts and nylon lock nuts. Do not tighten.
10. Mount top turnbuckle stub (see drawing on page 17 – item # 6) to center cross frame using 1/2" x 1-1/2" bolt with lock washer and turnbuckle end plate. Tighten securely.
11. Screw turnbuckle body (see drawing on page 17 – item # 5) onto top stub leaving 4" of thread showing. Screw in lower turnbuckle stub (see drawing on page 17 – item # 4). Leave about 4" of thread showing.
12. Mount wings to both sides of main frame bucket. Use 2-1/4" dia. Hinge Pin. Secure it in place with 3/8" X 4" NC Gr.5 Cap Screw, lock washer, and hex nut. Ensure that main frame bucket and wing buckets are lined up (see drawing on page 41).
13. Install truss rod mast frames. Center them and mount to the main frame using 3/4" x 2-1/2" NC Cap Screw with lock washers and hex nuts. Ensure that the hinge pin is secured with 3/8" x 3" NC Gr.5 Cap Screw with lock washers and hex nuts on top of the masts and the truss rod pivot bushings are in place before mounting truss rods (see drawing on page 41).
14. Mount cross brace to the truss rod mast frames using 5/8" U-Bolts with lock washers and hex nuts.
15. Mount long truss rod ends to the truss rod pivot bushings and short ends to the wing truss rod anchors. Adjust truss rod length to level wing buckets with main frame bucket.
16. Attach one of the ends of the top link ratchet (see drawing on page 43 – item # 6) to the main frame lockout ears using 1" x 4-1/2" bolt and secure with 1" lock washer and hex nut.
17. Fold the wing and place the other end of the top link ratchet between the lockout plates on the wing. Secure with 1" x 4-1/2" lockout pin and lynch pin (adjust ratchet length if needed). Tighten the top link ratchet for transport to eliminate any wing bucket movement (see drawing on page 43 - item # 6).

18. Repeat same procedure for the other side.
19. Push the tire axle (see drawing on page 11 – item # 22) under the main frame. Align the tire axle so that when mounted to the rear of the bucket, the cylinder anchors are on the backside toward the rear cross frame. Now push the tire axle up until the legs slide into the gussets on the rear of the bucket. Line up the holes and insert a 1" NC x 3-1/2" bolt with zerks, through each hole. Install a nylon lock nut on each bolt and tighten.
20. Install hydraulic pipe with attached flow divider from the back side of the machine sliding it under center cross frame toward the front. Place the second hydraulic pipe on top and secure with double pipe clamps.
21. Attach 3" x 8" welded hydraulic cylinders (see drawing on page 31 – item # 11) with rod ends facing away from bucket to the tire axle.
22. Install 41" hoses into the lower port of the cylinders and upper set of cross pipes. Install the 33" hoses into the upper port of the cylinders and the lower set of cross pipes. Use thread sealant on all pipe and hose joints. Support the piping with five double pipe clamps. Use five 5/16" NC x 2-1/2" bolts, lock washers and hex nuts.
23. Install two short cross rods between the center cross frame and the rear inside frame. Use two 5/8" NC x 2" bolts, lock washers and hex nuts at center cross frame and two 5/8" NC x 2" bolts, lock washers and hex nuts at the rear inside frame end. Leave the rod assemblies loose.
24. Now install the two long cross rods between the rear inside frame and the rear cross frame. Use two 5/8" NC x 2" bolts, lock washers and hex nuts at the rear end of the main frame and two 5/8" NC x 2" bolts, lock washers and hex nuts at the rear inside frame end. Leave the rod assemblies loose.
25. Tighten up all eight cross rod attaching bolts.
26. Tighten up all four cross rod turnbuckles sufficiently to square up the frames. Install the cross rod U-bolts (see drawing on page 11 – item # 35).
27. Make a final check of the assembled Land Leveler. Cross rods should be tightened. The jam nut should be locked up against the turnbuckle. The front turnbuckle must be adjusted correctly. Lock pins should be in place. Make sure all frame and cross member bolts are tight. 8" U-bolts must be tight and positioned correctly on the rear cross frame. Grease all zerk fittings prior to operation.

TO TRANSPORT FOLDING TRI PLANE ON THE ROAD:

1. Move the bucket to its lowest position and install the cylinder locking bars. The tire axle will be up and lock pins in place. Remove both lock pins from the tire axle. Lower the tire axle hydraulically until the lock pins can be reinserted into the same holes. This will lock the wheels into the transport position with the rear steel wheels off the ground.
2. Fold wing buckets forward and pin in place with red lockout pins provided. Tighten top link ratchets to eliminate any wing movement. Secure wings to the main frame using safety chains with hooks.
3. Fold rear steel wheel pivot frames back and pin in place with lockout pins provided.
4. Adjust the front turnbuckle to hookup to the tractor drawbar, and then readjust for the wheel/ground clearance desired.
5. Align the tongue with the frame center line; insert the pivot shaft lockout pin, with the wrench portion up, between the frames and through the rear hole of the front main frame pivot shaft.
6. **Do not try to move the Land Leveler on the road on its steel wheels. Always use the transport wheels when moving on roadways.**

TO LOWER LAND LEVELER FOR LAND LEVELING:

1. Lower the tire axle hydraulically enough to remove the locking pins. Raise the tire axle slowly until the front or rear wheels touch the ground. Adjust the front turnbuckle until the pins are free. Remove the turnbuckle and mount it on the left pull brace with two lynch pins.
2. If the machine does not have a hydraulically actuated bucket, lift arm locks must be used on each side.
3. Remove the pivot shaft lockout pin, the 1" shaft between the front ends of the frame; place it in the pin holder bracket at the front of the machine.
4. The bucket leveling and depth adjustments are made by adjusting the lift screws located on each side of the Land Leveler.
5. Unfold rear steel wheel frames and secure them in place with 1" X 3-1/2" cap screws with lock washers and hex nuts.
6. Loosen wing lockout ratchets to remove lockout pins and unfold wings. Adjust truss rod lengths if needed. Fasten wings to the main frame bucket mating plates with 1" x 2-1/2" cap screws with lock washers and hex nuts.
7. Check the rear wheels for travel alignment:
 - a. Loosen both stabilizer bearing cap screws to assure that the bearing or roller is free to move in the slot.
 - b. Stretch a string from the outside of one wheel rim to the outside of the opposite wheel rim approximately 14" off of and parallel to the ground.
 - c. Adjust each wheel so that the string touches the full surface of each wheel rim with no bend in the string. (Visually check from outside of one wheel to the outside of the other)
 - d. Retighten the bearing or roller cap screws in the stabilizer.
 - e. Remove the string and now the Land Leveler is ready to use.
6. Operating the machine under adverse conditions, such as extremely rough ground, rocks or stumps, may cause the hitch end bolt to break. If this occurs, do not replace the factory installed bolt with a case hardened bolt. It is intended to be a safety shear pin.
7. **Hydraulic Cylinder option.** Adjust cylinder adjusting screw, located on the piston end of the bucket cylinder, so that the pivot point (A) is located 1/8" forward of a direct line between the upper turnbuckle; attach point (B) and the lower attach point (C) on each side of the machine. (See Drawing on the following page)
8. Adjust the bucket lift turnbuckle to "Level", set blade and working height of the bucket.
9. Recheck adjustment No. 7 above, to make sure pivot point is within tolerance (0" to 1/8"). If necessary, readjust No. 7 and No. 8 above.



REF. NO.	PART NUMBER	DESCRIPTION	QTY.
1	SLPF-10L100	Bucket Weldment	1
2	SLP-00J100	Brace Weldment	1
3	SLPF-07L300	Wing Weldment	1
4	SLP-00J200	Pull Brace Weldment	2
5	SLP-00L200L	Bucket Side Weldment LH	1
	SLP-00L200R	Bucket Side Weldment RH (shown)	1
7	SLP-00L204	Bucket Side Adjustment Blade	1
11	SLP-07L125	Wing Bucket Blade Shim 7 Ft.	2
	SLP-10L125	Main Frame Bucket Blade Shim	1
12	SLP-07L124	Wing Bucket Double Blade 7 Ft.	2
	SLP-10L124	Main Frame Bucket Double Blade	1
13	PBNC-10028	5/8" X 1-3/4" NC Plow Bolt	25
14	LWASHER-10	5/8" Lock Washer	37
15	HXNUT-10NC	5/8" NC Hex Nut	37
16	CSNC510032	5/8" X 2" Gr.5 NC Cap Screw	12
17	CSNC512032	3/4" X 2" Gr.5 NC Cap Screw	4
18	LWASHER-12	3/4" Lock Washer	2
19	HXNUT-12NC	3/4" NC Hex Nut	2
20	CSNC516040	1" X 2-1/2" Gr.5 NC Cap Screw	6
21	LWASHER-16	1" Lock Washer	8
22	HXNUT-16NC	1" NC Hex Nut	8
23	CSNC506048	3/8" X 3" Gr.5 NC Cap Screw	1
24	LWASHER-06	3/8" Lock Washer	1
25	HXNUT-06NC	3/8" NC Hex Nut	1
26	CSNC516072	1" X 4-1/2" Gr.5 NC Cap Screw	2
27	SLPF-00K007L	Pull Arm Tie Bar L.H.	1
	SLPF-00K007R	Pull Arm Tie Bar R.H.	1
28	NYNUT-12NC	3/4" NC Nylon Lock Hex Nut	2
29	SLPF-00L804	Wing Hinge Pin	2
30	CSNC510040	5/8" X 2-1/2" Gr.5 NC Cap Screw	2
31	FWASHER-10	5/8" Flat Washer	6
32	SLPF-00F000	Truss Rod Mast Cross Bar	1
33	UBNC10X41S	5/8" NC Square U-Bolt	4
34	CSNC512040	3/4" X 2-1/2" NC Gr.5 Cap Screw	8
35	SLPF-00F100	Truss Rod Mast Pivot Bushing	2
36	SLPF-00L600	Truss Rod Long	2
38	GTB-12X96W	Turnbuckle Welded Ass'y (includes body and short rod)	2
41	GPN-12X040	3/4" X 2-1/2" Clevis Pin	2
42	GPN-040LYN	1/4" Lynch Pin	2

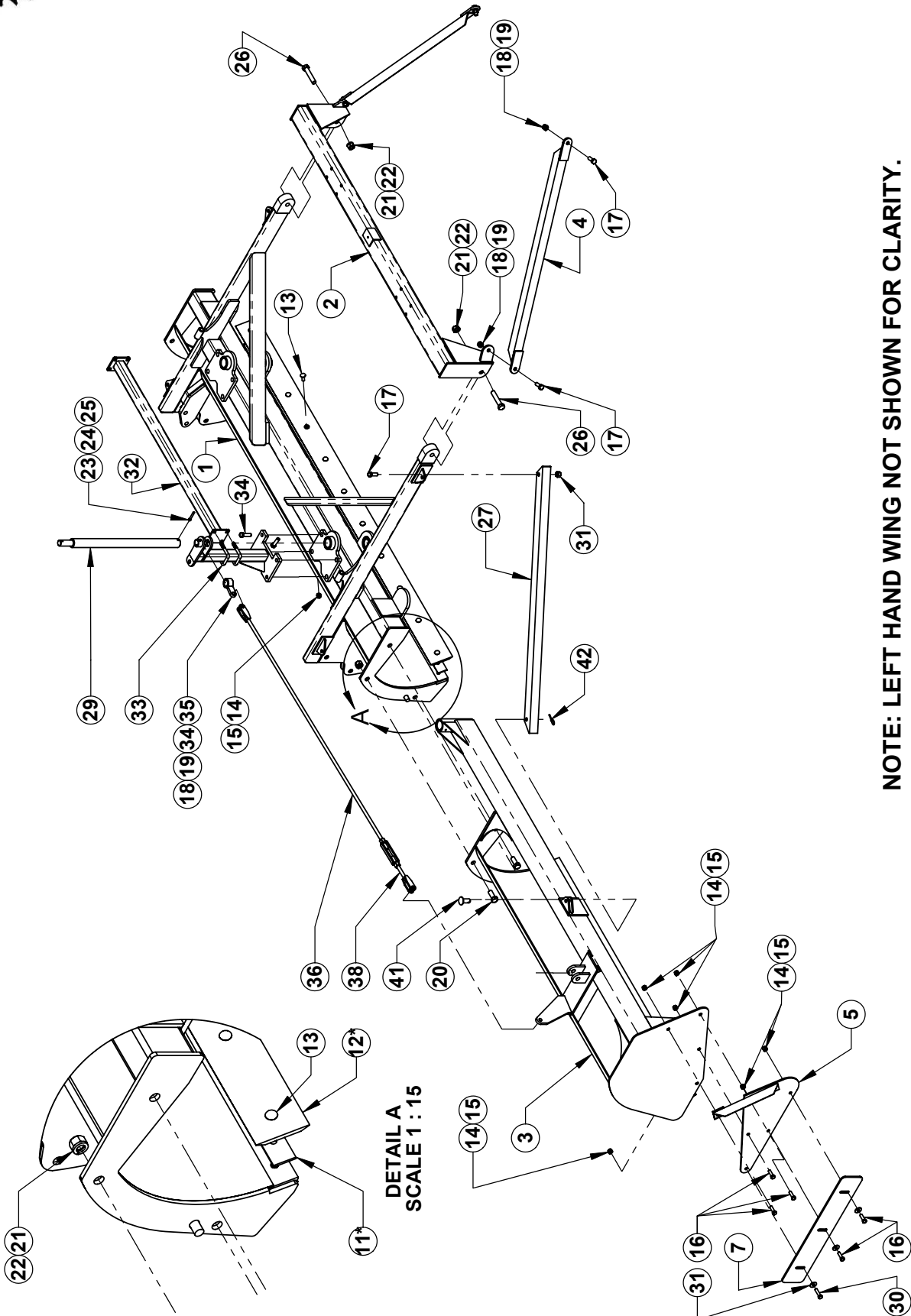

NOTE: LEFT HAND WING NOT SHOWN FOR CLARITY.

* DENOTES MULTIPLE PART CONFIGURATIONS

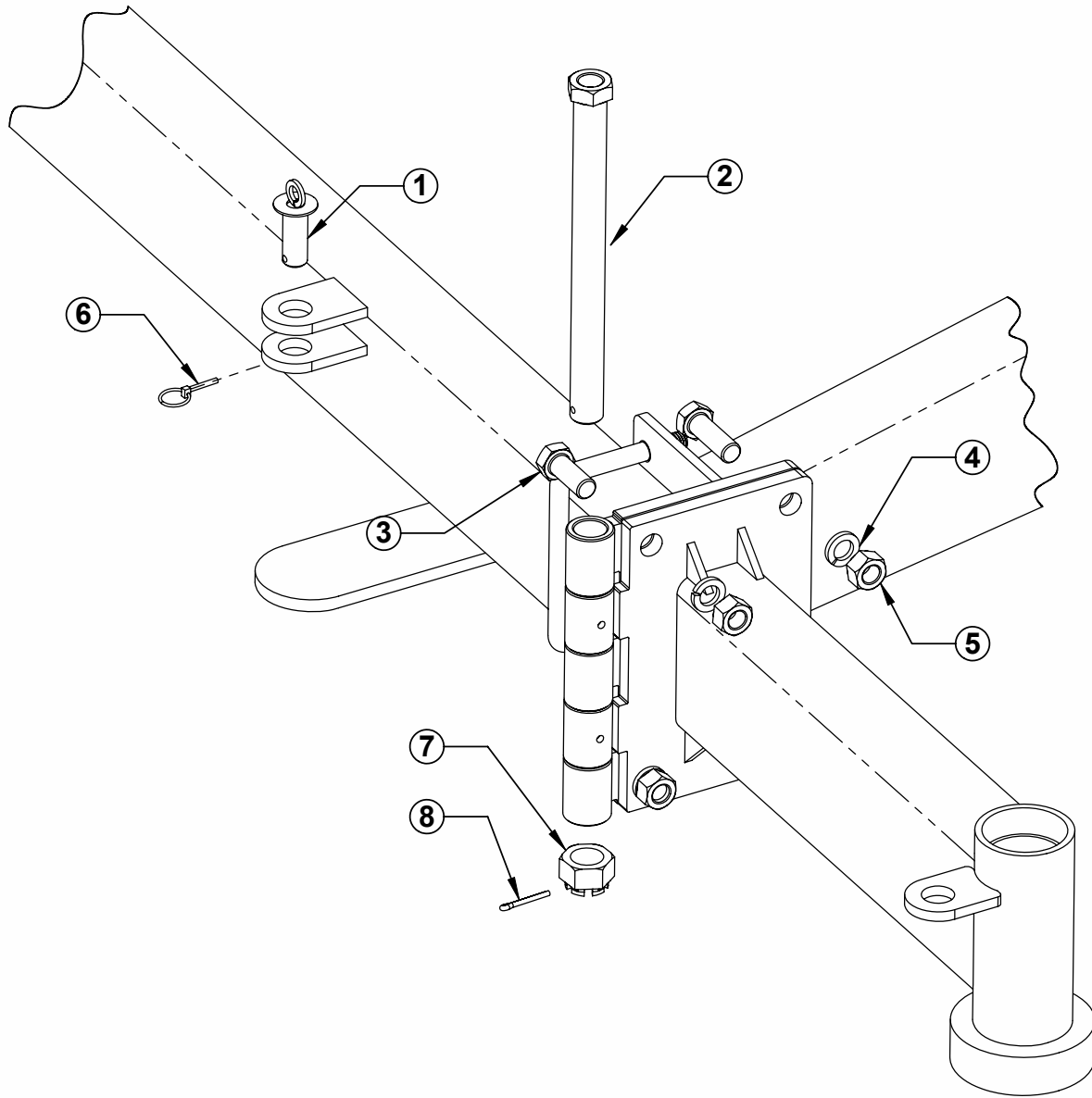

Ref. No.	Part Number	Description	Qty.
1	SLPF-00C400	Rear Lockout Pin Weldment	2
2	SLPF-00C500	Rear Hinge Pin 1-1/2"	2
3	CSNC516056	1" X 3-1/2" NC Gr.5 Cap Screw	8
4	LWASHER-16	1" Lock Washer	8
5	HXNUT-16NC	1" NC Hex Nut	8
6	GPN-040LYN	1/4" Lynch Pin	2
7	CANUT-24NF	1-1/2" NF Castle Hex Nut	2
8	GPN-04X40C	1/4" Cotter Pin	2

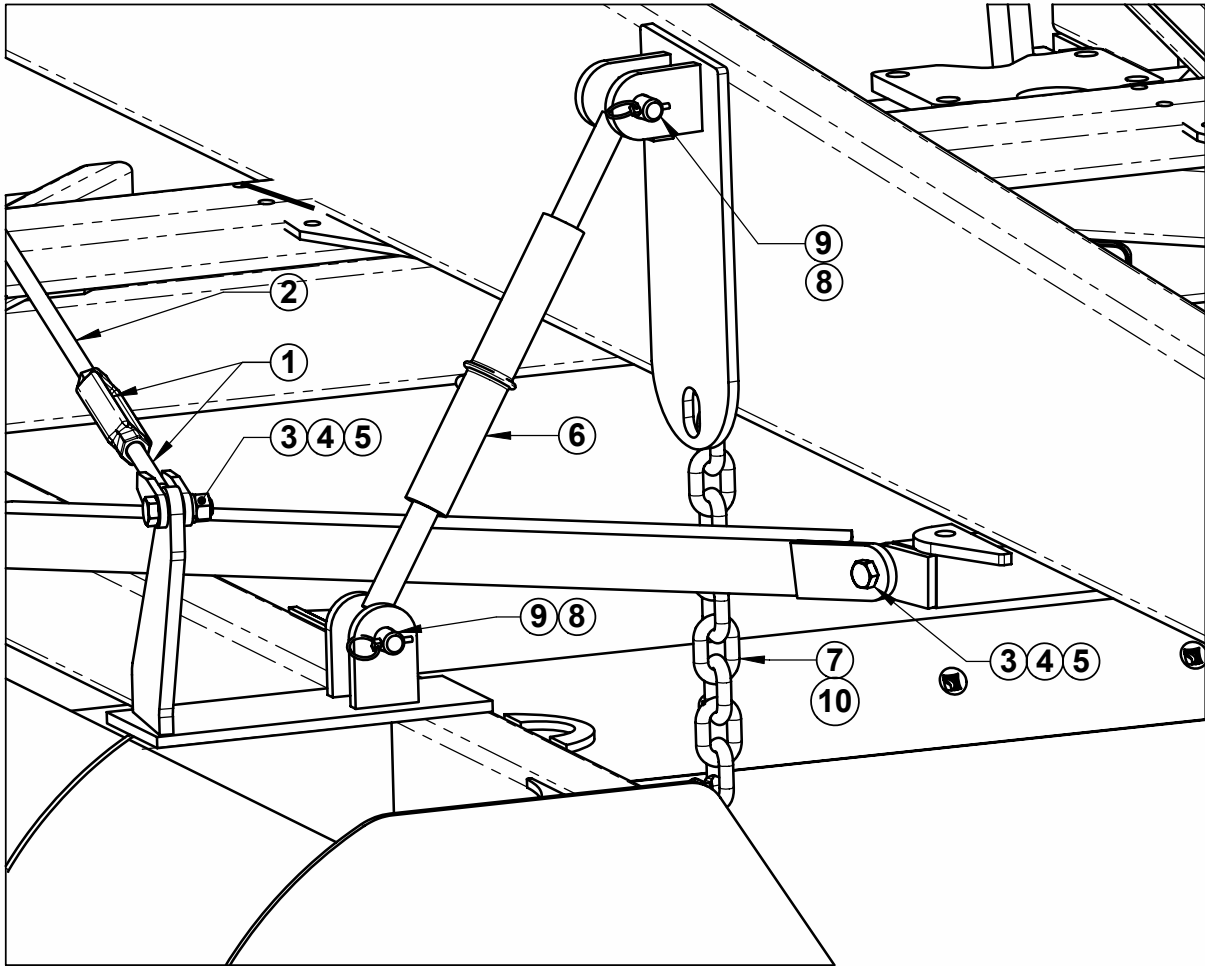

Item #	Part Number	Description	Qty.
1	GTB-12X96W	3/4" X 6" Turnbuckle Assembly (includes turnbuckle body and short rod)	2
2	SLPF-00F600	3/4" Long Truss Rod Weldment	2
3	CSNC512040	3/4" X 2-1/2" NC Gr.5 Cap Screw	4
4	LWASHER-12	3/4" Lock Washer	4
5	HXNUT-12NC	3/4" NC Hex Nut	4
6	GJK-CA0216	CA 2 Top Link Ratchet	2
7	GMB-CH05PC	5/16" Safety Chain (5 Ft. long)	2
8	GPN-040LYN	1/4" Lynch Pin	4
9	GPN-16X076	1" X 4-5/16" Top Link Pin	4
10	GMB-CH05HK	5/16" Chain Slip Hook	2

T.G. SCHMEISER CO., INC.®

Limited Warranty Statement

T. G. Schmeiser Co., Inc. warrants each new Schmeiser® product to be free from defects in material and workmanship. This warranty is applicable only for the normal service life expectancy of the product or components, not to exceed twelve (12) consecutive months from the date of delivery of the new Schmeiser product to the original purchaser.

Genuine T. G. Schmeiser Co., Inc. replacement parts and components will be warranted for 90 days from date of purchase, or the remainder of the original equipment warranty period, whichever is longer.

Under no circumstances will it cover any merchandise or components thereof, which, in the opinion of the company, has been subjected to misuse, unauthorized modifications, alteration, an accident or if repairs have been made with parts other than those obtainable through T. G. Schmeiser Co., Inc.

The Company in no way warrants engines, batteries, cylinders, tires or other trade accessories since these items are warranted separately by their respective manufacturer. Expendable components such as points, shanks, blades, rings, bearings, teeth, and the like are excluded from this warranty.

Our obligation under this warranty shall be limited to repairing or replacing, free of charge to the original purchaser, any part that, in our judgment, shall show evidence of such defect, provided further that such part shall be returned within thirty (30) days from date of failure to T. G. Schmeiser Co., Inc., routed through the dealer and distributor from whom the purchase was made, transportation charges prepaid.

This warranty shall not be interpreted to render T. G. Schmeiser Co., Inc. liable for injury or damages of any kind or nature to person or property. This warranty does not extend to the loss of crops, loss because of delay in harvesting, or any expense or loss incurred for labor, substitute machinery, rental or for any other reason.

Except as set forth above, **T. G. Schmeiser Co., Inc. shall have no obligation or liability of any kind on account of any of its equipment and shall not be liable for special or consequential damages. T. G. Schmeiser Co., Inc. makes no other warranty, expressed or implied, and, specifically, T. G. Schmeiser Co., Inc. disclaims any implied warranty or merchantability or fitness for a particular purpose. Some states or provinces do not permit limitations or exclusions of implied warranties or incidental or consequential damages, so the limitations or exclusion in this warranty may not apply.**

This warranty is subject to any existing conditions of supply, which may directly affect our ability to obtain materials or manufacture replacement parts.

T. G. Schmeiser Co., Inc. reserves the right to make improvements in design or changes in specifications at any time, without incurring any obligation to owners of units previously sold.

No one is authorized to alter, modify or enlarge this warranty nor the exclusion, limitations and reservations.

**WARRANTY VOID IF NOT REGISTERED
WITHIN 30 DAYS OF PURCHASE DATE**